

# Owner's Manual

## Operation & Care

**INSTALLER:** Leave this manual with party responsible for use and operation.  
**OWNER:** Retain this manual for future reference.

Contact your dealer with questions on installation, operation, or service.

**NOTICE: DO NOT DISCARD THIS MANUAL**

# QUADRA-FIRE®

**EXPEDITION II WOOD INSERT  
AUTOMATIC COMBUSTION  
CONTROL (ACC)**

**MODEL NUMBER:  
EXPEDITION-II**

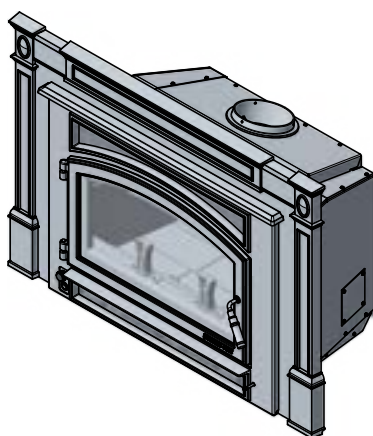
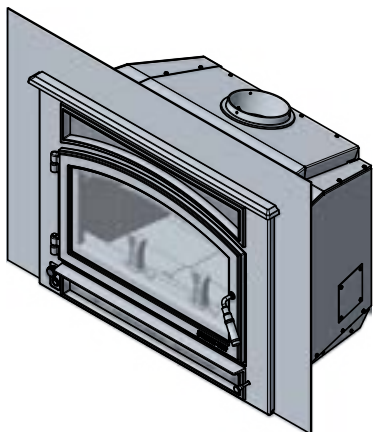

Installation and service of this appliance should be performed by qualified personnel. Hearth & Home Technologies recommends HHT Factory Trained or NFI certified professionals.



### WARNING



If the information in these instructions is not followed exactly, a fire may result causing property damage, personal injury, or death.

- Do not store or use gasoline or other flammable vapors and liquids in the vicinity of this or any other appliance.
- Do not over fire - If heater or chimney connector glows, you are over firing. Over firing will void your warranty.
- Comply with all minimum clearances to combustibles as specified.

Failure to comply may cause house fire.



### WARNING



#### HOT SURFACES!

Glass and other surfaces are hot during operation AND cool down.

**Hot glass and appliance will cause burns.**

- Do not touch glass until it is cooled
- Use leather gloves when reloading fuel
- NEVER allow children to touch glass
- Keep children away
- CAREFULLY SUPERVISE children in same room as appliance.
- Alert children and adults to hazards of high temperatures
- High temperatures may ignite clothing or other flammable materials.
- Keep clothing, furniture, draperies and other flammable materials away.



### WARNING



#### Fire Risk.

For use with solid wood fuel only.  
Other fuels may over fire and generate poisonous gases (i.e. carbon monoxide).

**NOTE:** To obtain a French translation of this manual, please contact your dealer or visit [www.quadrafire.com](http://www.quadrafire.com)

**REMARQUE :** Pour obtenir une traduction française de ce manuel, s'il vous plaît contacter votre revendeur ou visitez [www.quadrafire.com](http://www.quadrafire.com)

# Congratulations

## and Welcome to the Quadra-Fire Family!

**NOTE:** Clearances may only be reduced by means approved by the regulatory authority having jurisdiction

**A. Sample of Serial Number / Safety Label**  
 LOCATION: UNDER ASH LIP, PULL OUT TO VIEW

LISTED ROOM HEATER, SOLID FUEL TYPE  
**"For Use with Solid Wood Fuel Only."**  
 Also for use in Mobile Home.  
**PREVENT HOUSE FIRES**

Install and use only in accordance with manufacturer's installation, venting and operating instructions. CONTACT YOUR LOCAL BUILDING OR FIRE OFFICIALS ABOUT RESTRICTIONS AND INSTALLATION INSPECTION IN YOUR AREA. Refer to manufacturer's instructions and local codes for precautions required for passing chimney through a combustible wall or ceiling. **WARNING - For Mobile Homes:** Do not install in a sleeping room. An outside combustion air inlet must be provided and unrestricted while unit is in use. The structural integrity of the mobile home floor, ceiling and walls must be maintained. The insert must be properly grounded to the frame of the mobile home. A complete relining of the chimney system with a 6 inch (152mm) diameter listed stainless liner is required. Must be equipped with a spark arrestor cap. Outside Air comes standard on the insert and must be installed before operating insert.

When used as a masonry insert stove, install only in a masonry fireplace built to national and/or local codes. Do not remove brick or mortar to accommodate insert. Installation requires a 5 foot minimum length of a starter pipe into existing chimney with airtight face seal. A full reline with listed liner strongly recommended. Install only on a non-combustible hearth.

Approved for installation and use in factory built zero-clearance fireplaces conforming to minimum fire chamber specifications. A complete relining of the chimney system with a 6 inch (152mm) diameter listed stainless liner is required.

In Canada a full length 6 inch (152mm) S635 flue liner is required as per ULC S628-93. **WARNING -** Inspect and clean chimney frequently. Under certain conditions of use, creosote buildup may occur rapidly. Do not connect this unit to a chimney serving another appliance. **DANGER: Risk of electrical shock.** Disconnect power supply before servicing. Route power cord away from unit. Do not route cord over front of appliance. Electrical Rating: 115 VAC 1.4 AMPS 60 Hz. Do not use grate or elevate fire. Build wood fire directly on hearth (the fire should not overfire). If heater or chimney connector glows, you are overfiring. Operate with doors closed. Open only to add fuel to the fire. Replace grate only with 5mm ceramic available from your dealer.

Minimum Clearances to Combustible Material Masonry, Heat-Resistant Surfaces & Factory-Built	Factory-Built Floor Protection under Hearth Extension
Refer to Clearances on Owner Label for Canada	Thermal & Ember Protection
USA ONLY	Floor height 0 to 4.5 inches below Insert Base. Materials with R value of 2.9 required.
A. Firewall to top of side door 13.5 in.	Ember Protection Only
B. Firewall to top of bottom unit 47.75 in.	Greater than 4.5 inches below Insert Base.
C. Side trim to Fuel Loading Door 34.75 in.	
D. Side trim to Fuel Loading Door 13 in.	
E. Hearth Extension from Glass 16 in.	
F. Hearth Extension from Fuel Loading Door 8 in.	

**CAUTION: HOT WHILE IN OPERATION DO NOT TOUCH, KEEP CHILDREN, CLOTHING AND FURNITURE AWAY. CONTACT MAY CAUSE SKIN BURNS. SEE NAMEPLATE AND INSTRUCTIONS.**

0061WN100E

QUADRA-FIRE

EXPEDITION II

Serial No./N° de série

HF

CONFORMS TO UL 1482-2011 AND CERTIFIED TO ULCS110 S628-93

U.S. ENVIRONMENTAL PROTECTION AGENCY

Certified to comply with 2020 criteria wood particulate emission standards for single burn rate heaters. This single burn rate wood heater is not approved for use with a flue damper.

This wood heater needs periodic inspection and repair for proper operation. Consult the owner's manual for further information. It is against federal regulations to operate this wood heater in a manner inconsistent with the operating instructions in the owner's manual.

Mfg by:

HEARTH & HOME TECHNOLOGIES

352 Mountain House Road  
Hallifax, PA 99114  
www.quadrafire.com

2019	2020	JAN	FEB	MAR	APR	MAY	JUN
<input type="checkbox"/>	<input type="checkbox"/>	<input type="checkbox"/>	<input type="checkbox"/>	<input type="checkbox"/>	<input type="checkbox"/>	<input type="checkbox"/>	<input type="checkbox"/>
<input type="checkbox"/>	<input type="checkbox"/>	<input type="checkbox"/>	<input type="checkbox"/>	<input type="checkbox"/>	<input type="checkbox"/>	<input type="checkbox"/>	<input type="checkbox"/>
<input type="checkbox"/>	<input type="checkbox"/>	<input type="checkbox"/>	<input type="checkbox"/>	<input type="checkbox"/>	<input type="checkbox"/>	<input type="checkbox"/>	<input type="checkbox"/>

DO NOT REMOVE THIS LABEL

Made in U.S.A. or U.S. and imported parts.

Test Lab & Report Number

Serial Number

Model Name

Mfg Date



**Safety Alert Key:**

- **DANGER!** Indicates a hazardous situation which, if not avoided will result in death or serious injury.
- **WARNING!** Indicates a hazardous situation which, if not avoided may result in death or serious injury.
- **CAUTION!** Indicates a hazardous situation which, if not avoided, may result in minor or moderate injury.
- **NOTICE:** Indicates practices which may cause damage to the appliance or to property.

**TABLE OF CONTENTS**

A. Sample of Serial Number / Safety Label . . . . . 2  
 B. Warranty . . . . . 4  
 C. Quick Start Guide. . . . . 6

**1 Listing and Code Approvals**

A. Insert Safety Certification . . . . . 7  
 B. Insert Emissions Certification. . . . . 7  
 C. BTU & Efficiency Specifications. . . . . 7  
 D. Mobile Home Approved (USA only) . . . . . 8  
 E. Glass Specifications. . . . . 8  
 F. Sleeping Room . . . . . 8  
 G. California - Prop65. . . . . 8

**2 Operating Instructions**

A. Your Wood Appliance. . . . . 9  
 B. Fire Safety . . . . . 10  
 C. Over firing . . . . . 10  
 D. Combustible/Non-combustible Materials . . . . . 10  
 E. Seasoned Wood. . . . . 10  
 F. Burning Process . . . . . 11  
 G. Automatic Combustion Control (ACC). . . . . 11  
 H. Burn Rate and Operating Efficiency. . . . . 12  
 I. Wood Fuel . . . . . 12  
 J. Building A Fire. . . . . 13  
 K. Blower Control Box with Snap Disc . . . . . 14  
 L. Blower Operation . . . . . 14  
 M. Opacity (Smoke) . . . . . 14  
 N. Clear Space . . . . . 14  
 O. Negative Pressure. . . . . 15  
 P. Frequently Asked Questions. . . . . 15

**3 Maintenance and Service**

A. Quick Reference Maintenance Guide ..... 16  
 B. General Maintenance..... 17  
 C. Correct Baffle & Blanket Placement..... 19

**4 Troubleshooting Guide ..... 20**

**5 Service Parts Replacement**

A. Glass ..... 21  
 B. Firebrick ..... 21  
 C. Blower ..... 22  
 D. Snap Disc..... 22  
 E. Baffle Board ..... 23  
 F. Wiring Diagram ..... 23  
 G. Door Handle..... 23  
 H. Tube Channel..... 24

**6 Reference Materials**

A. Service and Maintenance Log..... 25  
 B. Exploded View ..... 29  
 → C. Service Parts..... 30  
 D. Accessories..... 34

→ = Contains updated information

## B. Warranty

### Hearth & Home Technologies LIMITED LIFETIME WARRANTY

Hearth & Home Technologies, on behalf of its hearth brands (“HHT”), extends the following warranty for HHT gas, wood, pellet and electric hearth appliances that are purchased from an HHT authorized dealer.

#### **WARRANTY COVERAGE:**

HHT warrants to the original owner of the HHT appliance at the site of installation, and to any transferee taking ownership of the appliance at the site of installation within two years following the date of original purchase, that the HHT appliance will be free from defects in materials and workmanship at the time of manufacture. After installation, if covered components manufactured by HHT are found to be defective in materials or workmanship during the applicable warranty period, HHT will, at its option, repair or replace the covered components. HHT, at its own discretion, may fully discharge all of its obligations under such warranties by replacing the product itself or refunding the verified purchase price of the product itself. The maximum amount recoverable under this warranty is limited to the purchase price of the product. This warranty is subject to conditions, exclusions and limitations as described below.

#### **WARRANTY PERIOD:**

Warranty coverage for consumers begins at the date of installation. In the case of new home construction, warranty coverage begins on the date of first occupancy of the dwelling or six months after the sale of the product by an independent, authorized HHT dealer/distributor, whichever occurs earlier. However, the warranty shall commence no later than 24 months following the date of product shipment from HHT, regardless of the installation or occupancy date. The warranty period for parts and labor for covered components is produced in the following table.

The term “Limited Lifetime” in the table below is defined as: 20 years from the beginning date of warranty coverage for gas appliances, and 10 years from the beginning date of warranty coverage for wood and pellet appliances. These time periods reflect the minimum expected useful lives of the designated components under normal operating conditions.

Warranty Period		HHT Manufactured Appliances and Venting					
Parts	Labor	Gas	Pellet	Wood	Electric	Venting	Components Covered
1 Year		X	X	X	X	X	All parts including handles, external enameled components and other material except as covered by Conditions, Exclusions, and Limitations listed
2 years			X	X			Igniters, Auger Motors, Electronic Components, and Glass
		X					Electrical components limited to modules, remotes/wall switches, valves, pilots, blowers, junction boxes, wire harnesses, transformers and lights (excluding light bulbs)
		X		X			Molded Refractory Panels, Glass Liners
3 years			X				Firepots, burnpots, mechanical feeders/auger assemblies
5 years	1 year	X					Vent Free Burners, Vent Free Logs
			X	X			Castings, Medallions and Baffles
6 years	3 years			X			Catalyst - Limitations Listed
7 years	3 years		X	X			Manifold tubes, HHT Chimney and Terminations
10 years	1 year	X					Burners, logs and refractory
Limited Lifetime	3 years	X	X	X			Firebox and heat exchanger, FlexBurn® System (engine, inner cover, access cover and fireback)
1 Year	None	X	X	X	X	X	All replacement parts beyond warranty period

See conditions, exclusions and limitations on the next page

## **WARRANTY CONDITIONS:**

- This warranty only covers HHT appliances that are purchased through an HHT authorized dealer or distributor. A list of HHT authorized dealers is available on the HHT branded websites.
- This warranty is only valid while the HHT appliance remains at the site of original installation.
- This warranty is only valid in the country in which the HHT authorized dealer or distributor that sold the appliance resides.
- Contact your installing dealer for warranty service. If the installing dealer or distributor is unable to provide necessary parts, contact the nearest HHT authorized dealer or supplier. Additional service fees may apply if you are seeking warranty service from a dealer other than the dealer from whom you originally purchased the product.
- Check with your dealer in advance for any costs to you when arranging a warranty call. Travel and shipping charges for parts are not covered by this warranty.
- Limited Catalyst Warranty
  - o For wood burning products containing a catalyst, the catalyst will be warranted for a six-year period to the original purchaser at the site of original installation. The purchaser must provide the name, address, and telephone number of the location where the product is installed, proof of original purchase date, date of failure, and any relevant information regarding the failure of the catalyst.

## **WARRANTY EXCLUSIONS:**

This warranty does not cover the following:

- Changes in surface finishes as a result of normal use. As a heating appliance, some changes in color of interior and exterior surface finishes may occur. This is not a flaw and is not covered under warranty.
- Damage to printed, plated, or enameled surfaces caused by fingerprints, accidents, misuse, scratches, melted items, or other external sources and residues left on the plated surfaces from the use of abrasive cleaners or polishes.
- Repair or replacement of parts that are subject to normal wear and tear during the warranty period are not covered. These parts include: paint, wood and pellet gaskets, firebricks, grates, flame guides, batteries and the discoloration of glass.
- Expansion, contraction, or movement of certain parts causing noise. These conditions are normal and complaints related to this noise are not covered by this warranty.
- Damages resulting from: (1) failure to install, operate, or maintain the appliance in accordance with the installation instructions, operating instructions, and listing agent identification label furnished with the appliance; (2) failure to install the appliance in accordance with local building codes; (3) shipping or improper handling; (4) improper operation, abuse, misuse, continued operation with damaged, corroded or failed components, accident, or improperly/incorrectly performed repairs (5) environmental conditions, inadequate ventilation, negative pressure, or drafting caused by tightly sealed constructions, insufficient make-up air supply, or handling devices such as exhaust fans or forced air furnaces or other such causes; (6) use of fuels other than those specified in the operation instructions; (7) installation or use of components not supplied with the appliance or any other components not expressly authorized and approved by HHT; (8) modification of the appliance not expressly authorized and approved by HHT in writing; and/or (9) interruptions or fluctuations of electrical power supply to the appliance.
- Non-HHT venting components, hearth connections or other accessories used in conjunction with the appliance.
- Any part of a pre-existing fireplace system in which an insert or a decorative gas appliance is installed.
- HHT's obligation under this warranty does not extend to the appliance's capability to heat the desired space. Information is provided to assist the consumer and the dealer in selecting the proper appliance for the application. Consideration must be given to the appliance location and configuration, environmental conditions, insulation and air tightness of the structure.

### **This warranty is void if:**

- The appliance has been over-fired, operated in atmospheres contaminated by chlorine, fluorine, or other damaging chemicals. Over-firing can be identified by, but not limited to, warped plates or tubes, deformation/warping of interior cast iron structure or components, rust colored cast iron, bubbling, cracking and discoloration of steel or enamel finishes.
- The appliance is subjected to prolonged periods of dampness or condensation.
- There is any damage to the appliance or other components due to water or weather damage which is the result of, but not limited to, improper chimney or venting installation.

## **LIMITATIONS OF LIABILITY**

- The owner's exclusive remedy and HHT's sole obligation under this warranty, under any other warranty, express or implied, or in contract, tort or otherwise, shall be limited to replacement, repair, or refund, as specified above. In no event will HHT be liable for any incidental or consequential damages caused by defects in the appliance. Some states do not allow exclusions or limitation of incidental or consequential damages, so these limitations may not apply to you. This warranty gives you specific rights; you may also have other rights, which vary from state to state. EXCEPT TO THE EXTENT PROVIDED BY LAW, HHT MAKES NO EXPRESS WARRANTIES OTHER THAN THE WARRANTY SPECIFIED HEREIN. THE DURATION OF ANY IMPLIED WARRANTY IS LIMITED TO DURATION OF THE EXPRESSED WARRANTY SPECIFIED ABOVE.

### C. Quick Start Guide

**NOTE:** These are generic drawings and may not represent your specific model.

**ITEMS NEEDED FOR FIRST FIRE:** 10 Pieces of Newspaper, 10-20 Pieces of Dry Kindling and Few Pieces of Dry Split Wood.

**ACTIVATE ACC**

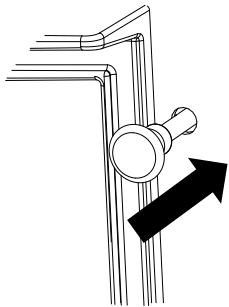

**1**

**LOAD WOOD**

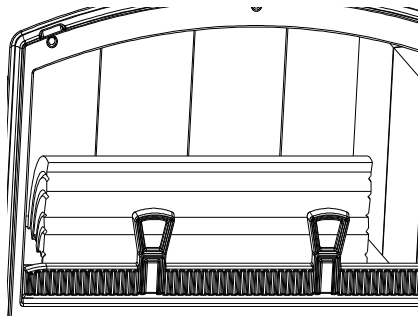

**2**

**ADD NEWSPAPER**

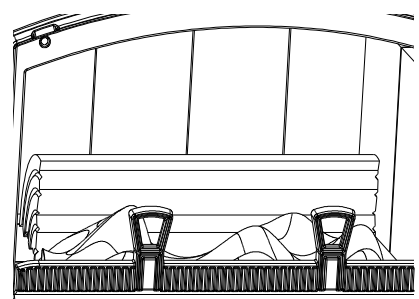

**3**

**ADD KINDLING**

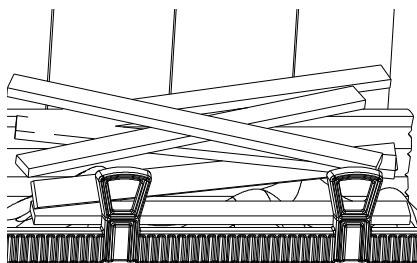

**LIGHT THE PAPER**

**4**

**Warning! Risk of Fire.**

Close and securely latch the door after the fire has started, and after refueling, to prevent:

- Spillage of smoke, flame and carbon monoxide
- Spillage of sparks, coals, and logs
- Over firing

DO NOT leave the appliance unattended with the door open.

Starting a fire may not require an open door for draft.

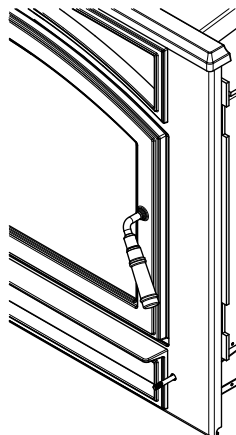

**5**

**ADD MORE WOOD**

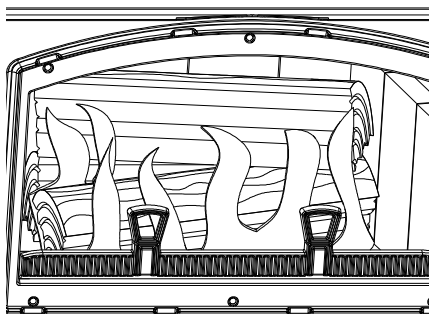

**6**

**ACTIVATE ACC**

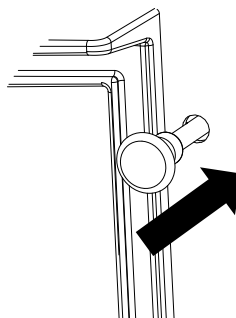

**7**

**The appliance is ready for normal operation.**

# 1 Listing and Code Approvals

## A. Insert Safety Certification

<b>Model Number:</b>	EXPEDITION-II
<b>Laboratory:</b>	OMNI Test Laboratories, Inc.
<b>Report Number:</b>	0061WN100S
<b>Type:</b>	Solid Fuel Type, Listed Room Heater
<b>Standard:</b>	UL1482 and ULC S628-93 and (UM) 84-HUD, Mobile Home Approved.

## B. Insert Emissions Certification

<b>Model Number:</b>	EXPEDITION-II
<b>Laboratory:</b>	OMNI Test Laboratories, Inc.
<b>Report Number:</b>	0061WN100E
<b>Standard:</b>	UL1482-2011
<b>Can be found at:</b>	<a href="http://www.quadrafire.com/about-us/epa-certification">www.quadrafire.com/about-us/epa-certification</a>

## C. BTU & Efficiency Specifications

<b>EPA Certification Number:</b>	Number: 199-19
<b>EPA Certified Emissions:</b>	1.9 grams per hour
<b>*LHV Tested Efficiency:</b>	77.0%
<b>**HHV Tested Efficiency:</b>	71.3%
<b>***EPA BTU Output:</b>	24,700 to 26,800 / hr
<b>****Peak BTU/Hour Output:</b>	56,000
<b>Vent Size:</b>	6 inches
<b>Firebox Size:</b>	2.37 cubic feet
<b>Recommended Wood Length:</b>	20 inches
<b>Fuel:</b>	Seasoned Cord Wood
* Weighted average LHV (Low Heating Value) efficiency using Douglas Fir dimensional lumber and data collected during EPA emission tests in accordance with the requirements of CSA B415.1. LHV assumes the moisture is already in a vapor state so there is no loss in energy to vaporize.	
** Weighted average HHV (High Heating Value) efficiency using Douglas Fir dimensional lumber and data collected during EPA emission tests in accordance with the requirements of CSA B415.1. HHV includes the energy required to vaporize the water in the fuel.	
*** A range of BTU outputs calculated using HHV Efficiency and the burn rates from the EPA tests, using Douglas Fir dimensional lumber.	
**** A peak BTU out of the appliance calculated using the maximum first hour burn rate from the High EPA Test and BTU content of seasoned cordwood (8600) times the efficiency.	

The EXPEDITION-II is Certified to comply with 2020 crib wood particulate emission standards.



This wood heater needs periodic inspection and repair for proper operation. It is against federal regulations to operate this wood appliance in a manner inconsistent with operating instructions in this manual.

**NOTE:** This installation must conform with local codes. In the absence of local codes you must comply with the **UL1482, (UM) 84-HUD and NPFA211 in the U.S.A. and the ULC S628-93 and CAN/CSA-B365 Installation Codes in Canada. NOT APPROVED FOR MOBILE HOME INSTALLATIONS IN CANADA!**

#### D. Mobile Home Approved (USA only)

- **WARNING:** DO NOT INSTALL IN A SLEEPING ROOM.
- **CAUTION:** THE STRUCTURE INTEGRITY OF THE MOBILE HOME FLOOR, WALL, AND CEILING/ROOF MUST BE MAINTAINED.
- The appliance must be properly grounded to the frame of the mobile home with #8 copper ground wire, and chimney must be listed to UL103 HT or a listed UL-1777 full length six inch (152mm) diameter liner must be used.
- Outside Air Kit, part OAK-ACC must be installed in a mobile home installation.

#### E. Glass Specifications

This stove is equipped with 5mm ceramic glass. Replace glass only with 5mm ceramic glass. Please contact your dealer for replacement glass.

#### F. Sleeping Room

When an appliance is installed in a sleeping room an outside air kit is required and it is recommended that a smoke and/or CO alarm be installed in the bedroom. The size of the room must be at least 50ft<sup>3</sup> per 1,000 Btu/hr stove input

#### G. California - Prop65



#### WARNING

This product and the fuels used to operate this product (wood), and the products of combustion of such fuels, can expose you to chemicals including carbon black, which is known to the State of California to cause cancer, and carbon monoxide, which is known to the State of California to cause birth defects or other reproductive harm. For more information go to: [WWW.P65Warnings.ca.gov](http://WWW.P65Warnings.ca.gov)



#### WARNING



#### Fire Risk.

Hearth & Home Technologies disclaims any responsibility for, and the warranty will be voided by, the following actions:

- Installation and use of any damaged appliance.
  - Modification of the appliance.
  - Installation other than as instructed by Hearth & Home Technologies.
  - Installation and/or use of any component part not approved by Hearth & Home Technologies.
  - Operating appliance without fully assembling all components.
  - Operating appliance without legs attached (if supplied with unit).
  - Do NOT Over fire - If appliance or chimney connector glows, you are over firing.
- Any such action that may cause a fire hazard.

Improper installation, adjustment, alteration, service or maintenance can cause injury or property damage.

For assistance or additional information, consult a qualified installer, service agency or your dealer.

Hearth & Home Technologies WILL NOT warranty stoves that exhibit evidence of over-firing. Evidence of over-firing includes, but is not limited to:

- Warped air tube
- Deteriorated refractory brick retainers
- Deteriorated baffle and other interior components

**NOTE:** Hearth & Home Technologies, manufacturer of this appliance, reserves the right to alter its products, their specifications and/or price without notice.



# User Guide

## 2 Operating Instructions



### WARNING

#### HOT SURFACES!

Glass and other surfaces are hot during operation AND cool down.



#### Hot glass will cause burns.

- Do not touch glass until it is cooled
- NEVER allow children to touch glass
- Keep children away
- CAREFULLY SUPERVISE children in same room as appliance.
- Alert children and adults to hazards of high temperatures.
- High temperatures may ignite clothing or other flammable materials.
- Keep clothing, furniture, draperies and other flammable materials away.

If you expect that children may come into contact with this appliance, we recommend a barrier such as a decorative screen. See your dealer for suggestions.

### A. Your Wood Appliance



### WARNING



Do not operate appliance before reading and understanding operating instructions. Failure to operate appliance according to operating instructions could cause fire or injury.

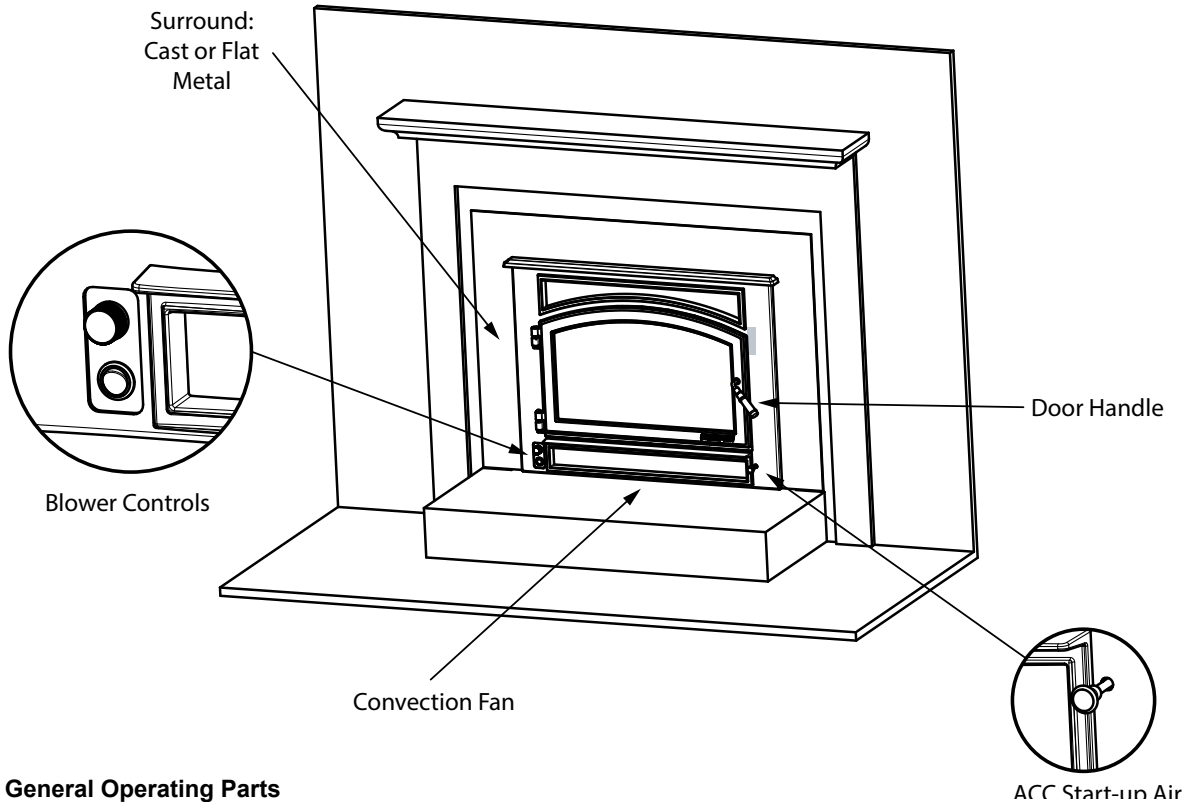



Figure 9.1 - General Operating Parts

## B. Fire Safety

To provide reasonable fire safety, the following should be given serious consideration:

1. Install at least one smoke detector on each floor of your home to ensure your safety. They should be located away from the heating appliance and close to the sleeping areas. Follow the smoke detector manufacturer's placement and installation instructions, and be sure to maintain regularly.
2. A conveniently located Class A fire extinguisher to contend with small fires resulting from burning embers.
3. A CO detector should be installed in the room with the appliance.
4. A practiced evacuation plan, consisting of at least two escape routes.
5. A plan to deal with a chimney fire as follows:
  - In the event of a chimney fire:
    - Evacuate the house immediately
    - Notify fire department.

## C. Over firing

	<b>WARNING</b>
	<b>Fire Risk.</b> <b>Do not over-fire.</b> Over-firing may ignite creosote or will damage the appliance and chimney. To prevent over-firing your appliance, <b>DO NOT:</b>
	<ul style="list-style-type: none"><li>• Use flammable liquids</li><li>• Overload with wood</li><li>• Burn trash or large amounts of scrap lumber</li><li>• Permit too much air to the fire</li></ul>

### 1. Symptoms of Over-Firing

Symptoms of over-firing may include one or more of the following:

- Chimney connector or appliance glowing
- Roaring, rumbling noises
- Loud cracking or banging sounds
- Metal warping
- Chimney fire

### 2. What To Do if Your Stove is Over-Firing

- Immediately close the door and air controls to reduce air supply to the fire.
- If you suspect a chimney fire, call the fire department and evacuate your house.
- Contact your local chimney professional and have your stove and stove pipe inspected for any damage.
- Do not use your stove until the chimney professional informs you it is safe to do so.

Hearth & Home Technologies WILL NOT warranty stoves that exhibit evidence of over-firing. Evidence of over-firing includes, but is not limited to:

- Warped air tube
- Deteriorated refractory brick retainers
- Deteriorated baffle and other interior components

## D. Combustible/Non-combustible Materials

### • Combustible Material

Material made of or surfaced with wood, compressed paper, plant fibers, plastics, or any material capable of igniting and burning, whether flame-proofed or not, plastered or non-plastered.

### • Non-combustible Material

Material which will not ignite and burn. Such materials are those consisting entirely of steel, iron, brick, tile, slate, glass or plasters, or any combination thereof.

### • Non-combustible Sealant Material

Sealants which will not ignite and burn: Rutland, Inc. Fireplace Mortar #63, Rutland 76R, Nuflex 304, GE RTV106 or GE RTB116 (or equivalent).

## E. Seasoned Wood

Burn only dry seasoned wood. Store wood under cover, out of the rain and snow. Dry and well-seasoned wood will not only minimize the chance of creosote formation, but will give you the most efficient fire. Even dry wood contains at least 15% moisture by weight, and should be burned hot enough to keep the chimney hot for as long as it takes to dry the wood out - about one hour. It is a waste of energy to burn unseasoned wood of any kind.

Dead wood lying on the forest floor should be considered wet, and requires full seasoning time. Standing dead wood can be considered to be about 2/3 seasoned. To tell if wood is dry enough to burn, check the ends of the logs. If there are cracks radiating in all directions from the center, it is dry. If your wood sizzles in the fire, even though the surface is dry, it may not be fully cured.

Splitting wood before it is stored reduces drying time. Wood should be stacked so that both ends of each piece are exposed to air, since more drying occurs through the cut ends than the sides. This is true even with wood that has been split. Store wood under cover, such as in a shed, or covered with a tarp, plastic, tar paper, sheets of scrap plywood, etc., as uncovered wood can absorb water from rain or snow, delaying the seasoning process.

## F. Burning Process

In recent years there has been an increasing concern about air quality. Much of the blame for poor air quality has been placed on the burning of wood for home heating. In order to improve the situation, we at Quadra-Fire have developed cleaner-burning wood appliances that surpass the requirements for emissions established by our governing agencies. These wood appliances must be properly operated in order to ensure that they perform the way they are designed to perform.

**NOTICE:** Improper operation can turn any wood appliance into a smoldering environmental hazard.

### 1. Kindling or First Stage

It helps to know a little about the actual process of burning in order to understand what goes on inside a appliance. The first stage of burning is called the kindling stage. In this stage, the wood is heated to a temperature high enough to evaporate the moisture which is present in all wood. The wood will reach the boiling point of water (212°F) and will not get any hotter until the water is evaporated. This process takes heat from the coals and tends to cool the appliance.

Fire requires three things to burn - fuel, air and heat. So, if heat is robbed from the appliance during the drying stage, the new load of wood has reduced the chances for a good clean burn. For this reason, it is always best to burn dry, seasoned firewood. The heat generated from the fire should be warming your home and establishing the flue draft, not evaporating the moisture out of wet, unseasoned wood, resulting in wasted heat.

### 2. Second Stage

The next stage of burning, the secondary stage, is the period when the wood gives off flammable gases which burn above the fuel with bright flames. During this stage of burning it is very important that the flames be maintained and not allowed to go out. This will ensure the cleanest possible fire.

### 3. Final Stage

The final stage of burning is the charcoal stage. This occurs when the flammable gases have been mostly burned and only charcoal remains. This is a naturally clean portion of the burn. The coals burn with hot blue flames.

It is very important to reload your appliance while enough lively hot coals remain in order to provide the amount of heat needed to dry and rekindle the next load of wood. It is best to activate the ACC before reloading (**Figure 11.1**). This livens up the coal bed and reduces excessive emissions (opacity/smoke). Open door slowly so that ash or smoke does not exit appliance through opening. You should also break up any large chunks and distribute the coals so that the new wood is laid on hot coals.

Air quality is important to all of us, and if we choose to use wood to heat our homes we should do so responsibly. To do this we need to learn to burn our appliances in the cleanest way possible. Doing this will allow us to continue using our wood appliances for many years to come.

## G. Automatic Combustion Control (ACC)

When using the Automatic Combustion Control (ACC) system, you do not have to continually monitor the fire. Once you set the ACC system it will control the fire for you. Follow the instructions below to learn how to operate your stove with ease.

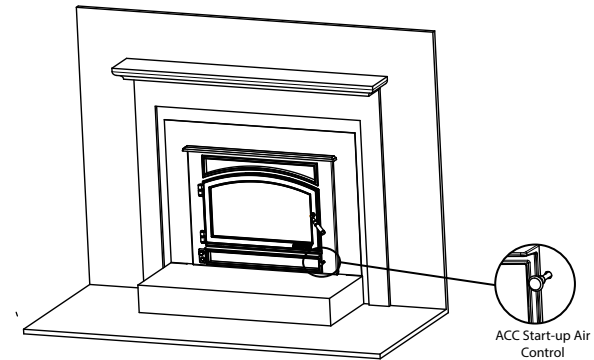



### To activate:

Push back until it stops and then pull forward until it stops

Figure 11.1

## H. Burn Rate and Operating Efficiency

	<b>WARNING</b>
	This wood appliance has a manufacturer-set minimum low burn rate that must not be altered. It is against federal regulations to alter this setting or otherwise operate this pellet insert in a manner inconsistent with operating instructions in this manual.

### For maximum operating efficiency

- Burn dry, well-seasoned wood.
- Follow these burn rate instructions below.

### Burn Rate

#### 1. Starting a Fire:

- Load appliance with wood and start fire (reference Quick Start Guide on page 7).
- Activate ACC.

#### 2. Reloading:



- Add wood as needed.
- Activate ACC.

#### 3. Adjusting the Burn Rate:

The Expedition II Insert is designed to optimize efficiency at all times. Since there are no user controls to adjust the burn rate, the easiest method is to learn how many logs you need at a time for the amount of heat desired. In addition to the amount of wood and the size of the logs, take the time to experiment with split and unsplit logs as split logs will burn faster than unsplit logs.

**NOTE:** If using the blower should be off for the first 30 minutes and then be operated in the desired setting at 30 minutes.

## I. Wood Fuel

	<b>WARNING</b>
	<b>Fire Risk.</b> <ul style="list-style-type: none"><li>• DO NOT BURN GARBAGE OR FLAMMABLE FLUIDS SUCH AS GASOLINE, NAPHTHA OR ENGINE OIL.</li><li>• Do NOT burn treated wood or wood with salt (driftwood).</li><li>• May generate carbon monoxide if burn material other than wood.</li></ul> May result in illness or possible death.

### **Hardwood vs Softwood**

Your appliance performance depends on the quality of the firewood you use.



- Seasoned wood contains about 8,000 BTUs per pound.
- Hard woods are more dense than soft woods.
- Hard woods contain 60% more BTUs than soft woods.
- Hard woods require more time to season, burn slower and are harder to ignite.
- Soft woods require less time to dry, burn faster and are easier to ignite.
- Start the fire with softwood to bring the appliance up to operating temperature and to establish draft.

- Add hardwood for slow, even heat and longer burn time.

HARDWOODS	SOFTWOODS
Alder	Aspen
Apple	Cedar
Birch	Douglas Fir
Maple	Pine
Oak	Spruce
Poplar	

### **Processed Solid Fuel Fire Logs**

- NOT permitted for use in this appliance
- ### **Moisture**

	<b>WARNING</b>
	<b>Fire Risk.</b> <ul style="list-style-type: none"><li>• Do NOT burn wet or green wood.</li><li>• Store wood in dry location.</li><li>• Stack wood so both ends are exposed to air.</li></ul> Wet, unseasoned wood can cause accumulation of creosote.

The majority of the problems appliance owners experience are caused by trying to burn wet, unseasoned wood.

- Wet, unseasoned wood requires energy to evaporate the water instead of heating your home, and
- Causes evaporating moisture which cools your chimney, accelerating formation of creosote.

### **Seasoned Wood**



- Cut logs to size
- Split to 6 inches (152 mm) or less in diameter
- Air dry to a moisture content of not more than 20%
  - Softwood - about nine months to dry
  - Hardwood - about eighteen months to dry

**NOTICE:** Seasoning time may vary depending on drying conditions.

### **Storing Wood**

Steps to ensure properly seasoned wood:

- Stack wood to allow air to circulate freely around and through woodpile.
- Elevate wood pile off ground to allow air circulation underneath.
- Smaller pieces of wood dry faster. Any piece over 6 in. (152 mm) in diameter should be split.
- Wood (whole or split) should be stacked so both ends of each piece are exposed to air. More drying occurs through the cut ends than the sides.
- Store wood under cover to prevent water absorption from rain or snow. Avoid covering the sides and ends completely.

	<b>WARNING</b>
	<b>Fire Risk</b> <p>Do NOT store wood:</p> <ul style="list-style-type: none"><li>• In front of the appliance.</li><li>• In space required for loading or ash removal.</li></ul>

## J. Building A Fire

Before lighting your first fire in the appliance:

**NOTE:** The special high temperature paint that your appliance is finished with will cure as your appliance heats. You will notice an odor and perhaps see some vapor rise from the appliance surface; this is normal. We recommend that you open a window until the odor dissipates and paint is cured.

1. Confirm the baffle and ceramic blanket are correctly positioned. They should be even with the front tube and resting on all tubes (**Figure 13.1 and Figure 13.2**).
2. Remove all labels from glass.

There are many ways to build a fire. The basic principle is to light easily-ignitable tinder or paper, which ignites the fast burning kindling, which in turn ignites the slow-burning firewood.

Here is one method that works well:

1. Activate ACC.
2. Load 1 or 2 small pieces of dry split wood into the firebox floor.
3. Place several wads of crushed paper on top of the dry split wood.
4. Lay small dry sticks of kindling on top of the paper.
5. Make sure that no matches or other combustibles are in the immediate area of the appliance. Be sure the room is ventilated and the flue unobstructed.
6. Light the paper in the appliance. NEVER light or rekindle fire with kerosene, gasoline, or charcoal lighter fluid; the results can be fatal.
7. Once the kindling is burning quickly, add several full-length logs 3 to 4 inches (76 - 102mm) in diameter. Be careful not to smother the fire. Stack the pieces of wood 1/2 to 1 inch apart (13-25mm); near enough to keep each other hot, but far enough away from each other to allow air flow between them.
8. Activate the timer system (ACC).
  - This livens up the coal bed and reduces excessive emissions (opacity/smoke).
  - Open door slowly so that ash or smoke does not exit appliance through opening.
  - Large logs burn slowly, holding a fire longer.
  - Small logs burn fast and hot, giving quick heat.
9. As long as there are hot coals, repeating steps 6 through 7 will maintain a continuous fire.

Fuel reloading:

1. **This appliance has a large door with an exceptional view of the fire.**
  - Door opens 26 inches (660mm) which goes beyond the standard size hearth pad covering the floor in front of the appliance.
  - May want to use a hearth rug in front of the hearth pad to protect the flooring from ash spillage and continuous cleaning of carpet, etc.

2. **Open door slowly so that ash or smoke does not exit appliance through opening.**

- Check the level of the ash build-up. Remove ash if it reaches the top of the brick covers. Ash should not be spilling over the brick covers onto the ash lip.
- Any ash or coals on the ash lip can be pressed into the door gasket and shorten the life of the gasket.
- If the ash is left to accumulate on the ash lip it can interfere with the door closing and/or falling out onto the hearth pad or beyond.

Check the ash level each time you reload.

**NOTE:** Build fire on brick firebox floor. Do NOT use grates, andirons or other methods to support fuel. It will adversely affect emissions.



### WARNING



#### Fire Risk.

##### Do NOT store wood:

- Closer than required clearances to combustibles to appliance
- Within space required for loading or ash removal.

##### Do NOT operate appliance:

- With appliance door open.
- With ash removal system door open.

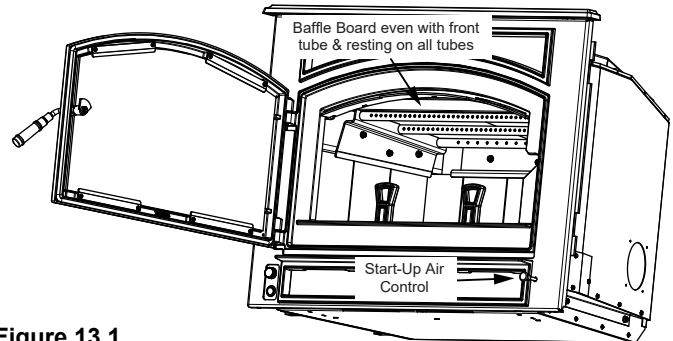

Figure 13.1

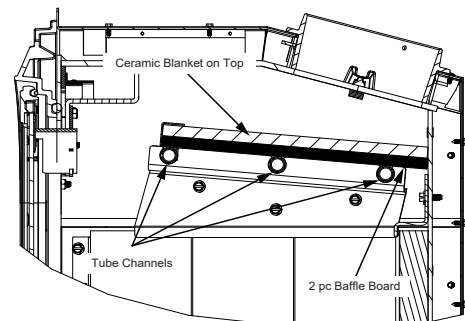

Figure 13.2



### WARNING



#### Fire Risk.

- Do NOT burn wet or green wood.
- Store wood in dry location.
- Stack wood so both ends are exposed to air.

Wet, unseasoned wood can cause accumulation of creosote.

## K. Blower Control Box with Snap Disc

1. The blower will turn on/off automatically when set to **AUTO (Figure 14.1)**.
2. When set to **MANUAL**, the fan will turn on/off only. This setting over-rides the internal snap disc.
3. Adjust the speed of the fan by turning the **HIGH/LOW** knob to the desired setting.

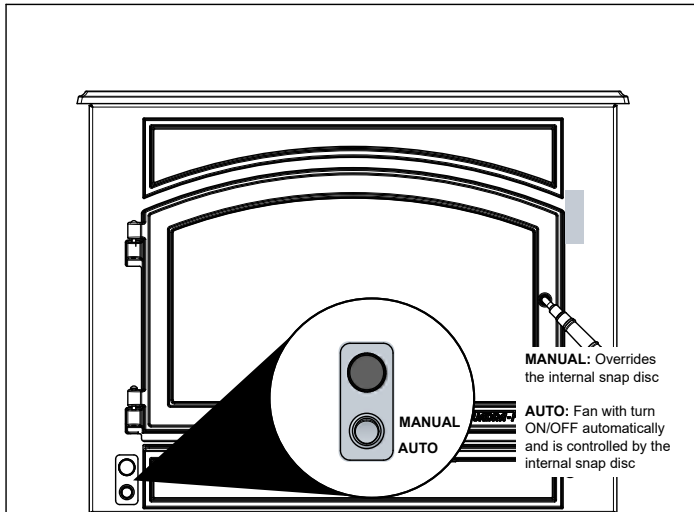

Figure 14.1

## L. Blower Operation

### 1. Initial (cold) startup:

Push the Start-up Air Control back until it stops. The blower tends to cool the appliance. Leave the blower off until the burn is well established, i.e., 30 minutes.

**NOTE:** For maximum efficiency and lowest emissions, when operating the blower in either the automatic or manual setting for the blower off until the burn is well established, i.e., 30 minutes.

2. The blower is equipped with five setting switch. Increase blower speed by turning the setting knob clockwise.

## M. Opacity (Smoke)

Opacity is the measure of how cleanly your appliance is burning. Opacity is measured in percent; 100% opacity is when an object is totally obscured by the smoke column from a chimney, and 0% opacity means that no smoke column can be seen. As you become familiar with your appliance, you should periodically check the opacity. This will allow you to know how to burn as nearly smoke-free as possible (goal of 0% opacity).

**CAUTION**

When burning your first fire, you will experience smoke and odor from the appliance resulting from the curing of paint and burning off of any oils remaining from manufacturing.

**Open windows during initial burn to dissipate smoke and odors!**

- Odors may be irritating to sensitive individuals.
- Smoke detectors may activate.

**NOTICE:** Do NOT operate a circulating fan within close proximity, approximately 4 ft (1.2m), of appliance. Can reverse air flow, blowing hot air into appliance cavity. Can damage appliance blower due to overheating.

## N. Clear Space

- Do NOT place combustible objects within 4 ft (1.2 m) of the front of appliance (**Figure 14.2**).
- **Mantel:** Avoid placing candles and other heat-sensitive objects on mantel or hearth. Heat may damage these objects.

**WARNING**

Do NOT place combustible objects in front of the appliance. High temperatures may ignite clothing, furniture or draperies.

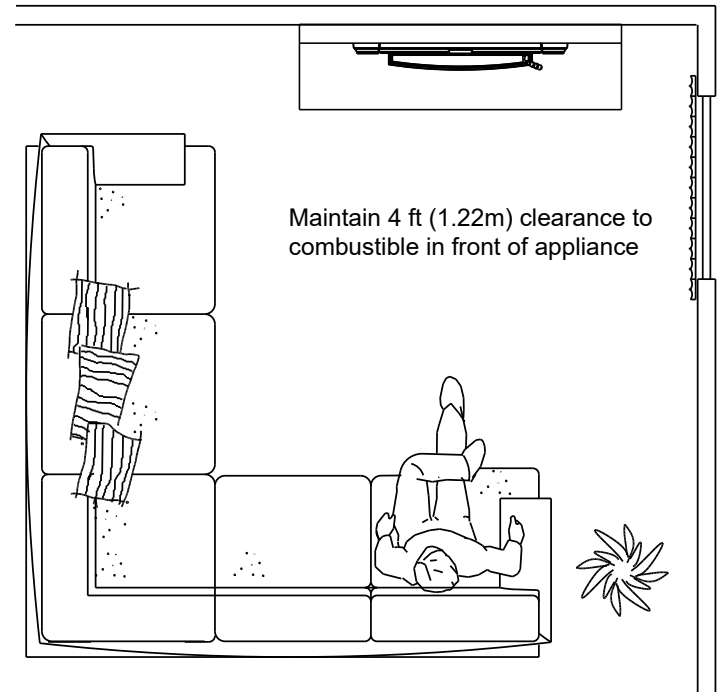



Figure 14.2

## O. Negative Pressure

	<b>WARNING</b>
	<p><b>Asphyxiation Risk.</b></p> <ul style="list-style-type: none"> <li>Negative pressure can cause spillage of combustion fumes, soot and carbon monoxide.</li> <li>Appliance needs to draft properly for safety.</li> </ul>

Negative pressure results from the imbalance of air available for the appliance to operate properly. It can be strongest in lower levels of the house.

### Causes include:

- Exhaust fans (kitchen, bath, etc.)
- Range hoods
- Combustion air requirements for furnaces, water appliances and other combustion appliances
- Clothes dryers
- Location of return-air vents to furnace or air conditioning
- Imbalances of the HVAC air handling system
- Upper level air leaks such as:
  - Recessed lighting
  - Attic hatch
  - Duct leaks

### To minimize the effects of negative air pressure:

- Install the outside air kit with the intake facing prevailing winds during the heating season
- Ensure adequate outdoor air for all combustion appliances and exhaust equipment
- Ensure furnace and air conditioning return vents are not located in the immediate vicinity of the appliance
- Avoid installing the appliance near doors, walkways or small isolated spaces
- Recessed lighting should be a “sealed can” design
- Attic hatches weather stripped or sealed
- Attic mounted duct work and air handler joints and seams taped or sealed



	<b>CAUTION</b>
<p>Do NOT operate a circulating fan within close proximity, approximately 4 ft (1.2m), of appliance:</p> <ul style="list-style-type: none"> <li>Can reverse air flow, blowing hot air into appliance cavity.</li> <li>Can damage appliance blower due to overheating.</li> </ul>	



## P. Frequently Asked Questions

ISSUES	SOLUTIONS
Odor from appliance	When first operated, this appliance may release an odor for the first several hours. This is caused by the curing of the paint and the burning off of any oils remaining from manufacturing.
Metallic noise	Noise is caused by metal expanding and contracting as it heats up and cools down, similar to the sound produced by a furnace or heating duct. This noise does not affect the operation or longevity of the appliance.
Whirring sound	If the blower has been installed, the blower produces a whirring sound which increases in volume as the speed is increased.

**CONTACT YOUR DEALER for additional information regarding operation and troubleshooting.**  
 Visit [www.quadrafire.com](http://www.quadrafire.com) to find a dealer.

Table 15.1

	<b>WARNING</b>
	<p><b>Fire Risk.</b></p> <ul style="list-style-type: none"> <li>DO NOT BURN GARBAGE OR FLAMMABLE FLUIDS SUCH AS GASOLINE, NAPHTHA OR ENGINE OIL.</li> <li>Do NOT burn treated wood or wood with salt (driftwood).</li> <li>May generate carbon monoxide if burn material other than wood.</li> </ul> <p>May result in illness or possible death.</p>

	<b>WARNING</b>
	<p><b>Fire Risk.</b></p> <p>Keep combustible materials, gasoline and other flammable vapors and liquids clear of appliance.</p> <ul style="list-style-type: none"> <li>Do NOT store flammable materials in the appliance's vicinity.</li> <li>DO NOT USE GASOLINE, LANTERN FUEL, KEROSENE, CHARCOAL LIGHTER FLUID OR SIMILAR LIQUIDS TO START OR “FRESHEN UP” A FIRE IN THIS Appliance.</li> <li>Keep all such liquids well away from the appliance while it is in use.</li> <li>Combustible materials may ignite.</li> </ul>

# 3 Maintenance and Service

## A. Quick Reference Maintenance Guide

When properly maintained, your fireplace will give you many years of trouble-free service. Contact your dealer to answer questions regarding proper operation, troubleshooting and service for your appliance. Visit [www.quadrafire.com/owner-resources](http://www.quadrafire.com/owner-resources) to view basic troubleshooting, FAQs, use & care videos.



## CAUTION

Allow the appliance to completely cool down before performing any cleaning or maintenance. Start the first inspection after the first 2 months of use, or if performance changes, and adjust your schedule accordingly. Maintenance is required for safe operation and must be performed to maintain your warranty.

	FREQUENCY	TASK
<p><b>Baffle &amp; Blanket</b></p>	<p>MONTHLY or after every one (1) cord of wood</p>	<p>Baffle and blanket placement is critical to heat output, efficiency and overall life of the appliance. Make sure the baffle is pushed all of the way to the back of the firebox and the blanket is laying flat. Inspect baffle for cracks.</p>
<p><b>Blower</b></p>	<p>YEARLY or after every four (4) cords of wood</p>	<p>Vacuum the blower impellers.</p>
<p><b>Chimney System</b></p>	<p>EVERY TWO MONTHS or after every four (4) cords of wood</p>	<p>The chimney and chimney cap must be inspected for soot and creosote every two months during the burn season or more frequency if chimney exceeds or is under 14-16 ft (4.3m-4.8m) measured from bottom of appliance.</p> <p>This will prevent pipe blockage, poor draft, and chimney fires. Always burn dry wood to help prevent cap blockage and creosote build-up.</p>
<p><b>Firebrick &amp; Ash Removal</b></p>	<p>WEEKLY or after every 25 loads of wood</p>	<p>Ashes must be cool before you can dispose of the ashes in a non-combustible container.</p> <p>Firebrick is designed to protect your firebox. After ashes are removed, inspect the firebrick and replace firebricks that are crumbling, cracked or broken.</p>
<p><b>Door &amp; Glass Assemblies</b></p>	<p>WEEKLY or after every 25 loads of wood</p>	<p>Keep door and glass gasket in good shape to maintain good burn. <b>To test:</b> place a dollar bill between the appliance and door and then shut the door. If you can pull the dollar out, remove one washer from door handle behind latch cam and try again. If you can still pull it out, replace the door gasket.</p> <p>Check the glass frame for loose screws to prevent air leakage.</p> <p>Check glass for cracks.</p>
<p><b>Door Handles</b></p>	<p>WEEKLY or after every 25 loads of wood</p>	<p>Check the door latch for proper adjustment. This is very important especially after the door rope has formed to the appliance face.</p> <p>Check door handle for smooth cam operation.</p>

Table 16.1

*These are generic drawings and may not represent your model.*



## B. General Maintenance

### 1. Creosote (Chimney) Cleaning

- **Frequency:** Every 2 months during heating season or as recommended by a certified chimney sweep; more frequently if chimney exceeds or is under 14-16 ft. (measured from bottom of appliance)
- **By:** Certified Chimney Sweep

Remove all ash from the firebox and extinguish all hot embers before disposal. Allow the appliance to cool completely. Disconnect flue pipe or remove baffle and ceramic blanket from appliance before cleaning chimney. Otherwise residue can pile up on top of the baffle and ceramic blanket and the appliance will not work properly. (See **Baffle Board** on [page 23](#)). Close the door tightly. The creosote or soot should be removed with a brush specifically designed for the type of chimney in use. Clean out fallen ashes from the firebox.

It is also recommended that before each heating season the entire system be professionally inspected, cleaned and repaired if necessary.

#### Inspection:



Inspect the system at the appliance connection and at the chimney top. Cooler surfaces tend to build creosote deposits quicker, so it is important to check the chimney from the top as well as from the bottom.



#### Formation and Need For Removal:

When wood is burned slowly, it produces tar and other organic vapors which combine with expelled moisture to form creosote.

The creosote vapors condense in the relatively cool chimney flue of a newly-started or a slow-burning fire. As a result, creosote residue accumulates on the flue lining. When ignited, this creosote creates an extremely hot fire which may damage the chimney or even destroy the house.



The chimney connector and chimney should be inspected once every 2 months during the heating season to determine if a creosote or soot buildup has occurred. If creosote or soot has accumulated, it should be removed to reduce the risk of a chimney fire.

 <b>WARNING</b>	
	<b>Fire Risk.</b> Prevent creosote buildup.
	<ul style="list-style-type: none"><li>• Inspect chimney connector and chimney once every two months during heating season.</li><li>• Remove creosote to reduce risk of chimney fire.</li><li>• Ignited creosote is extremely HOT.</li></ul>



 <b>WARNING</b>	
	<b>Fire Risk.</b>
	<ul style="list-style-type: none"><li>• Do not use chimney cleaners or flame colorants in your appliance. Will corrode chimney pipe.</li></ul>

### 2. Disposal of Ashes

- **Frequency:** When ash is within 1-3/4 in. (44mm) of firebox lip
- **By:** Homeowner

 <b>WARNING</b>	
	<b>Fire Risk.</b> Ashes could contain hot embers.

Ashes should be placed in a metal container with a tight fitting lid. The closed container of ashes should be placed on a non-combustible floor or on the ground, well away from all combustible materials, pending final disposal. If the ashes are disposed of by burial in soil or otherwise locally dispersed, they should be retained in the closed container until all cinders have thoroughly cooled.

 <b>WARNING</b>	
	<b>Fire Risk. Disposal of Ashes</b>
	<ul style="list-style-type: none"><li>• Ashes should be placed in metal container with tight fitting lid.</li><li>• Do not place metal container on combustible surface.</li><li>• Ashes should be retained in closed container until all cinders have thoroughly cooled.</li></ul>

### 3. Appliance Inspection

- **Frequency:** Every 2 months at the same time the chimney and chimney connector are inspected.
- **By:** Homeowner

#### Check for:

- Cracks in glass
- Door handle - smooth cam operation
- Baffle and ceramic blanket correct placement
- Baffle for warp-age
- Firebrick for cracks, broken or crumbly
- Door gasket (Dollar bill test): Place a dollar bill between the stove and the door and then shut the door. If you can pull the dollar bill out, replace the door gasket.
- Glass frame for loose screws

#### 4. Glass Cleaning

- **Frequency:** As desired
- **By:** Homeowner



### CAUTION

**Handle glass assembly with care. Glass is breakable.**

- Avoid striking, scratching or slamming glass
- Avoid abrasive cleaners
- Do not clean glass while it is hot

Clean glass with a non-abrasive glass cleaner. Abrasive cleaners may scratch and cause glass to crack. If the deposits on the glass are not very heavy, normal glass cleaners work well. Heavier deposits may be removed by using a damp cloth dipped in wood ashes or by using a commercially available oven cleaner.

After using an oven cleaner, it is advisable to remove any residue with a glass cleaner or soap and water. Oven cleaner left on during the next firing can permanently stain the glass and damage the finish on metal surfaces.

A portion of the combustion air entering the firebox is deflected down over the inside of the door glass. This air flow “washes” the glass, helping to keep smoke from adhering to its surface.

#### 5. Cleaning Plated Surfaces

- **Frequency:** Prior to first burn and then as desired
- **By:** Homeowner



### CAUTION

Do not use polishes with abrasives. It will scratch plated surfaces.

Clean all the fingerprints and oils from plated surfaces **BEFORE** firing the appliance for the first time. If not cleaned properly before lighting your first fire, the oils can cause permanent markings on the plating.

After the plating is cured, the oils will not affect the finish and little maintenance is required. Wipe clean as needed.

#### 6. Inspect Firebrick

- **Frequency:** After each ash removal
- **By:** Homeowner

Replace the firebrick if they become crumbly and/or if there is a 1/4 inch (6.35mm) gap between the bricks.

The firebox is lined with firebrick, which has exceptional insulating properties. Do not use a grate; simply build a fire on the firebox floor. Do not operate appliance without firebrick.

1. After the coals have completely cooled, remove all old brick and ash from unit and vacuum firebox.
2. Remove new brick set from box and lay out to the diagram shown in the instructions that come with the brick set or refer to the diagram on the service parts list at the end of this manual.
3. Lay bottom bricks in unit.
4. Install rear bricks on the top of the bottom bricks. Slide top of bricks under clip on back of firebox wall and push bottom of bricks back.
5. Install side bricks. Slide top of brick under clips on side of firebox and push the bottom of the brick until it is flush with the side of the unit.

## C. Correct Baffle & Blanket Placement



### WARNING

#### Fire Risk.

Firebox damage due to improper baffle placement is not covered by warranty. Operate the wood burning appliance with the baffle in the correct position only.



Not doing so could result in:

- Reduced efficiency
- Overheating the chimney
- Overheating the rear of the firebox
- Poor performance

Ensure correct baffle placement and replace baffle components if damaged or missing.



### CAUTION

The baffle boards are FRAGILE. Use extreme caution when loading firewood to prevent:

- Cracking, breaking or damaging the baffle boards
- DO NOT operate the appliance without baffle boards

**NOTE:** A missing, damaged or improperly positioned baffle is dangerous and may cause damage and poor efficiency. It will also void your warranty.

**NOTE:** These are generic drawings and may not represent your specific model.

## CORRECT POSITION

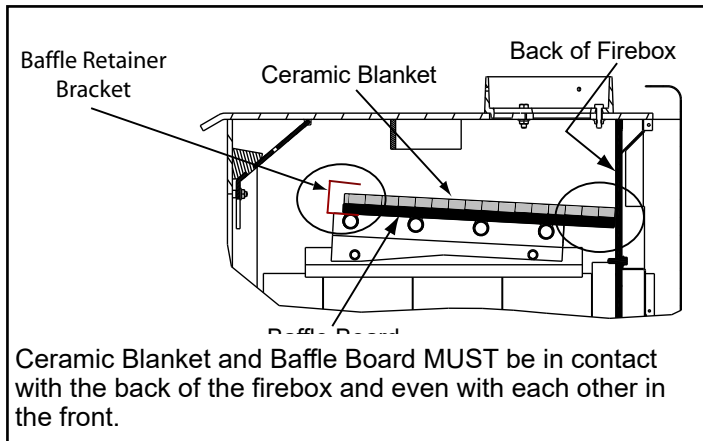
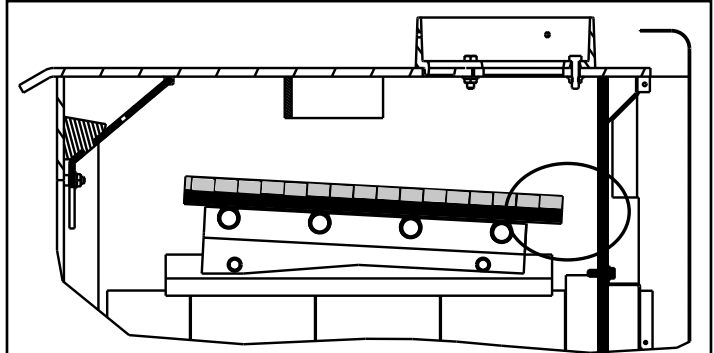
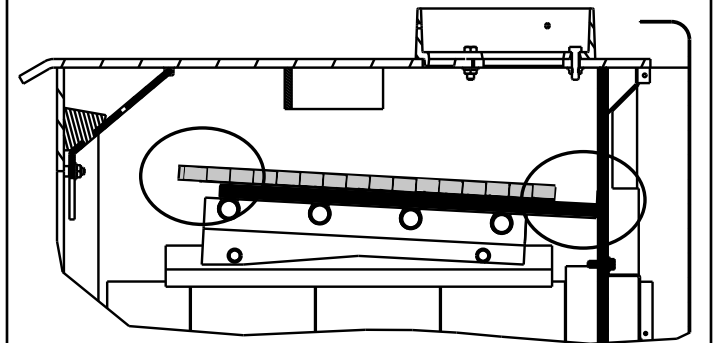

Figure 19.1

## INCORRECT POSITIONS



Ceramic Blanket and Baffle Board are NOT in contact with the back of the firebox.



Ceramic Blanket is NOT in contact with the back of the firebox and NOT even with the Baffle Board in the front.

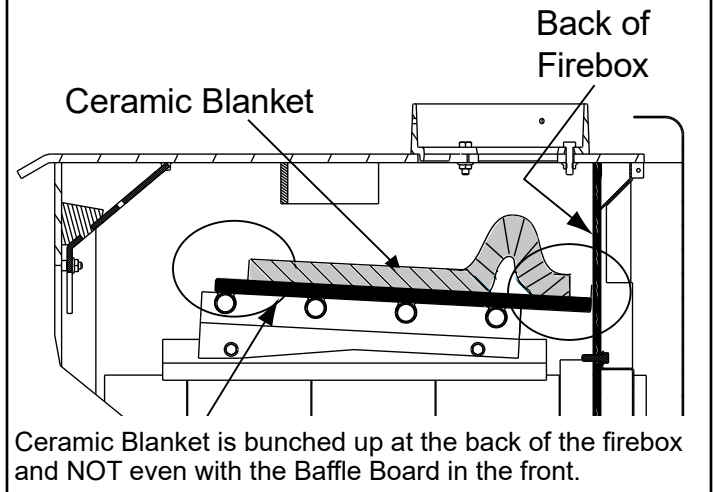

Figure 19.2

# 4 Troubleshooting Guide

With proper installation, operation, and maintenance your wood appliance will provide years of trouble-free service. If you do experience a problem, this troubleshooting guide will assist you or a qualified service person in the diagnosis of a problem and the corrective action to be taken.

Start Fire Problems	Possible Cause	Solution
Can not get fire started Excessive smoke or spillage Burns too slowly Not enough heat output	Not enough kindling/paper or no kindling/paper	Use dry kindling, more paper. Arrange kindling & wood for air movement.
	Not enough air for fire to ignite	Check for restricted termination cap
		Check for blockage of outside air kit; if installed.
		Check for flue blockage.
		Pre-warm flue before starting fire (refer to <b>Building a Fire</b> on <a href="#">page 13</a> ).
		Check for adequate vent height (refer to <b>Chimney Height / Rise and Run</b> on <a href="#">page 14</a> in the <i>Installation manual</i> ).
	Open window below the appliance towards the wind.	
	Wood condition is too wet, too large	Use dry, seasoned wood (refer to <b>Seasoned Wood</b> on <a href="#">page 10</a> ).
	Bed of coals not established before adding wood	Start with paper & kindling to establish bed of coals (refer to <b>Building a Fire</b> on <a href="#">page 13</a> ).
Flue blockage such as birds' nests or leaves in termination cap	Have chimney inspected for creosote and cleaned by a certified chimney sweep.	
Down draft or negative pressure Competition with exhaust devices	Do not use exhaust fans during start-up (refer to <b>Negative Pressure</b> on <a href="#">page 15</a> ).	
	Open window below the appliance towards the wind.	
Fire burns too fast	Extremely dry or soft wood	Mix in hardwood.
		Mix in less seasoned wood after fire is established (refer to <b>Wood Fuel</b> on <a href="#">page 12</a> ).
	Over drafting	Check for correct vent height; too much vertical height creates over drafting.
		Check location of vent termination (refer to <b>Chimney Termination Requirement</b> on <a href="#">page 13</a> in the <i>Installation manual</i> ).

Table 20.1

# 5 Service Parts Replacement

## A. Glass

**NOTE: Replace with 5mm ceramic glass only.**

**Service Part: SRV7095-054**

1. Ensure that the fire is out and the appliance is cool to the touch.
2. Protect a table or counter top with padding or towels. Protect your hands and wear gloves to prevent injury.
3. Remove the door with the broken glass by lifting the door up and off of the hinges.
4. Lay door face down on a table or counter making sure the handle hangs over the edge so the door lays flat, on a soft surface.
5. Remove the screws from each glass retainer and remove the glass. (If screws are difficult to remove, soak with penetrating oil first).
6. Center the glass with edges evenly overlapping the opening in the door, (i.e. same space top and bottom, left and right sides).
7. Replace the glass retainers. Be careful not to cross thread the screws.
8. Tighten each retainer just a few turns until each is secured. Check again for centering of glass in door frame. Continue to tighten each retainer alternately, a few turns at a time, until the glass is secure.

**NOTE: DO NOT OVER TIGHTEN RETAINERS - can cause glass to break.**

9. Replace the door on the appliance.

Quadra-Fire appliances are equipped with ceramic super heat-resistant glass, which can only be broken by impact or misuse.



### WARNING



#### Injury Risk.

- Use only glass specified in manual.
- DO NOT REPLACE with any other material.



### CAUTION

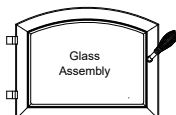

Handle glass assembly with care.  
**When cleaning glass:**

- Avoid striking, scratching or slamming glass.
- Do NOT clean glass when hot.
- Do NOT use abrasive cleaners.
- Use a hard water deposit glass cleaner on white film.
- Use commercial oven cleaner on heavier deposits.
- Remove all residue of oven cleaner or will permanently stain glass on next firing.

**Refer to maintenance instructions.**

## B. Firebrick

**Service Part: SRV7095-022**

Replace the firebrick if they become crumbly and/or if there is a 1/4 inch (6.35mm) gap between the bricks.

Inspect the firebrick after each ash removal.

The firebox is lined with high quality firebrick, which has exceptional insulating properties. There is no need to use a grate; simply build a fire on the firebox floor. Do not operate appliance without firebrick.

1. After the coals have completely cooled, remove all old brick and ash from appliance and vacuum firebox.
2. Remove new brick set from box and lay out to diagram shown.
3. Lay bottom bricks in appliance.
4. Install rear bricks on the top of the bottom bricks. Slide top of bricks under clip on back of firebox wall and push bottom of brick back.
5. Install side bricks. Slide top of brick under clips on side of firebox and push the bottom of the brick until it is flush with the side of the appliance.

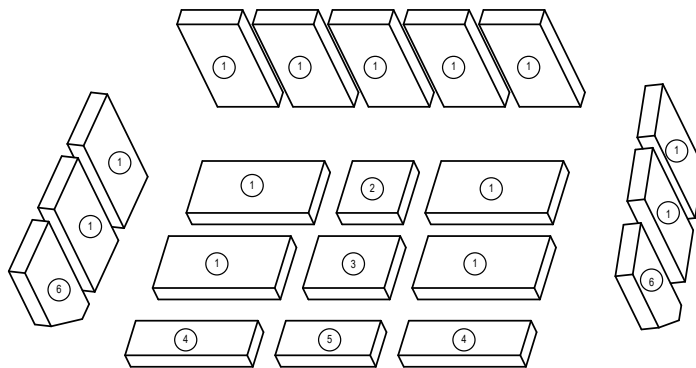

Figure 21.1

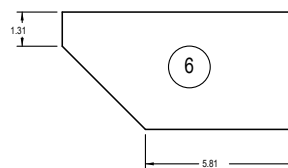

Figure 21.2



Placement	Dimensions	Qty Required
1	9" x 4.5" x 1.25"	13
2	4.5" x 4.5" x 1.25"	1
3	5.75" x 4.5" x 1.25"	1
4	9" x 3" x 1.25"	2
5	7" x 3" x 1.25"	1
6	9" x 4.5" x 1.25" w/Angle	2

Table 21.1

## C. Blower

Service Part: SRV7000-868

1. Ensure that the fire is out and the appliance is cool to the touch.
2. Remove the door by lifting the door up and off of the hinges; set aside (**Figure 22.1**).
3. Remove the fascia by lifting up and off of the appliance; set aside (**Figure 22.1**).
4. Disconnect the wires from the blower (**Figure 22.2**).
5. Remove the 2 screws from the hold down bracket and pull the blower and bracket forward.
6. Remove the blower from the hold down bracket.
7. Re-install in reverse order. Be certain that the hold down bracket's screws are completely seated in the grommets. Insert the locating tab in the hold down bracket into the placement slot.

	<b>CAUTION!</b>
	<b>Shock Risk.</b>
	• Do NOT remove grounding prong from plug.
	• Plug directly into properly grounded 3 prong receptacle.
	• Route cord away from appliance.
	• Do NOT route cord under or in front of appliance.

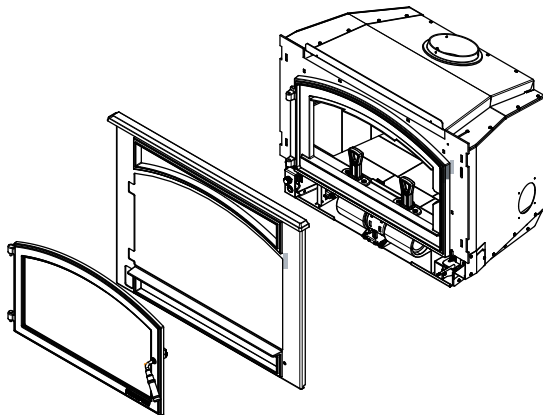

Figure 22.1

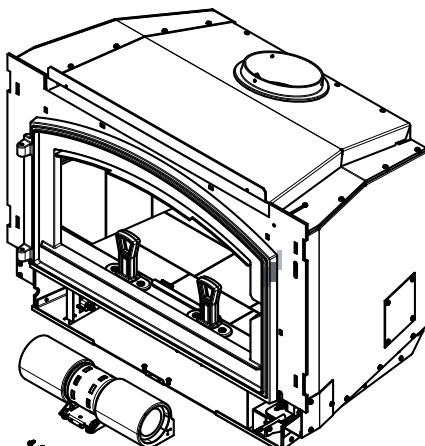

Figure 22.2

## D. Snap Disc

Service Part: SRV230-0470

1. Ensure that the fire is out and the appliance is cool to the touch.
2. Remove the door by lifting the door up and off of the hinges; set aside (**Figure 22.1**).
3. Remove the fascia by lifting up and off of the appliance; set aside (**Figure 22.1**).
4. Remove the 2 screws from the blower access assembly and slide assembly away from the appliance.
5. Using a Phillips head screw driver, remove the 2 screws from the snap disc and lift the snap disc off of the mounting bracket (**Figure 22.3**).
6. Disconnect the wires and replace with new snap disc and re-connect the wires.
7. Slide the blower assembly back into position and secure with the 2 mounting screws.

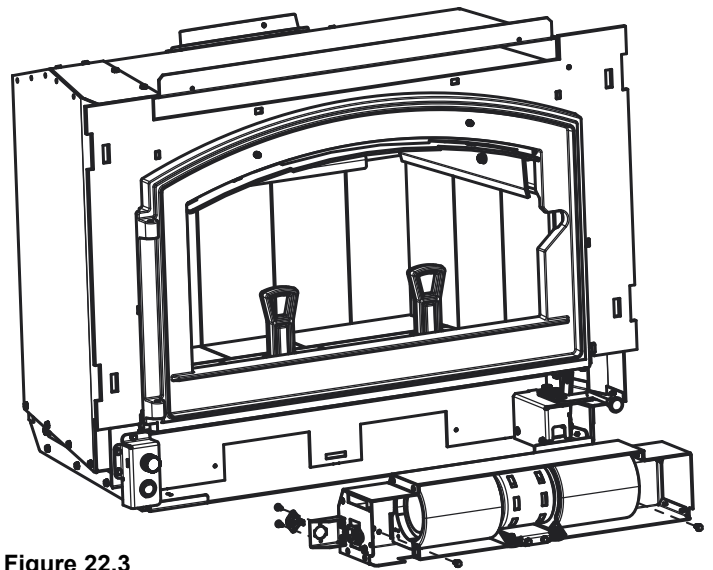

Figure 22.3

## E. Baffle Board

Service Part: SRV7095-117

1. Remove all ash from the firebox, and extinguish all hot embers before disposal into a metal container.
2. It is easier to remove both baffle boards and ceramic blanket after the tube channel assembly has been partially disassembled and the right side lowered. Follow steps 1 through 4 on page 25 for removal of the tube channel assembly. It is not necessary to completely remove the tube channel assembly.
3. Once the baffle protection cover has been removed, pull the baffle boards and ceramic blanket forward about 1 inch (25mm) and then overlap the baffles about 1-2 inches (25-51mm) (**Figure 23.1**).
4. Slide the tube channel assembly to the left as far as it will go and lower the right side. Remove the baffle boards and ceramic blanket together (**Figure 23.2**).
5. Re-install in reverse order. Be sure the baffle boards and ceramic blanket are in their proper positions (Reference **Correct Baffle & Blanket Placement** on [page 19](#)).

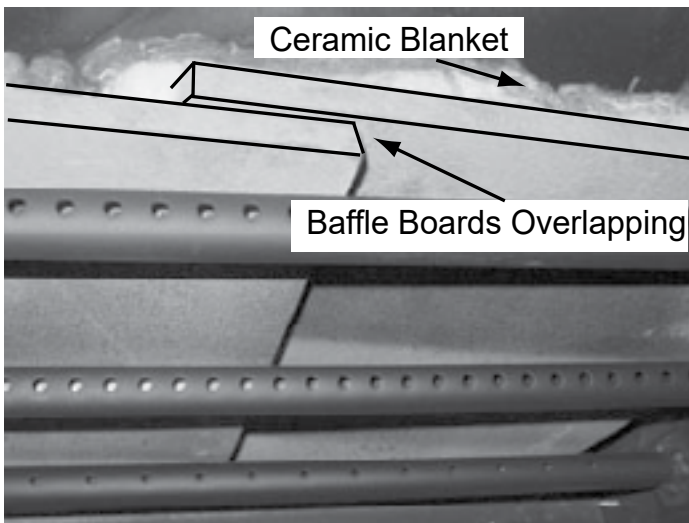

Figure 23.1

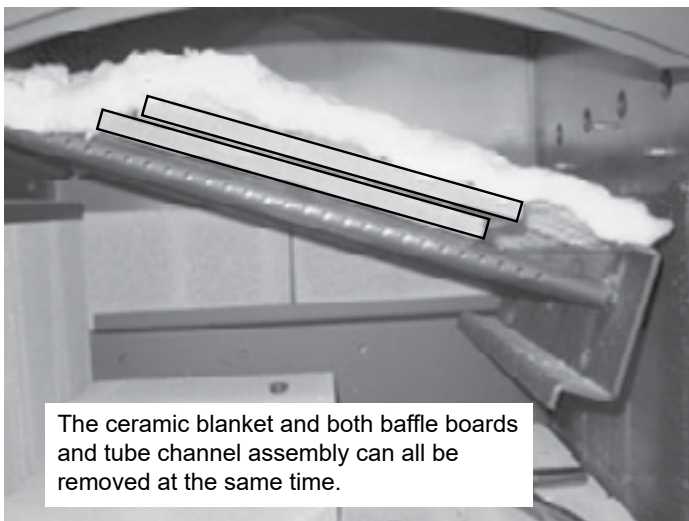

Figure 23.2

## F. Wiring Diagram

Service Part: SRV7000-891

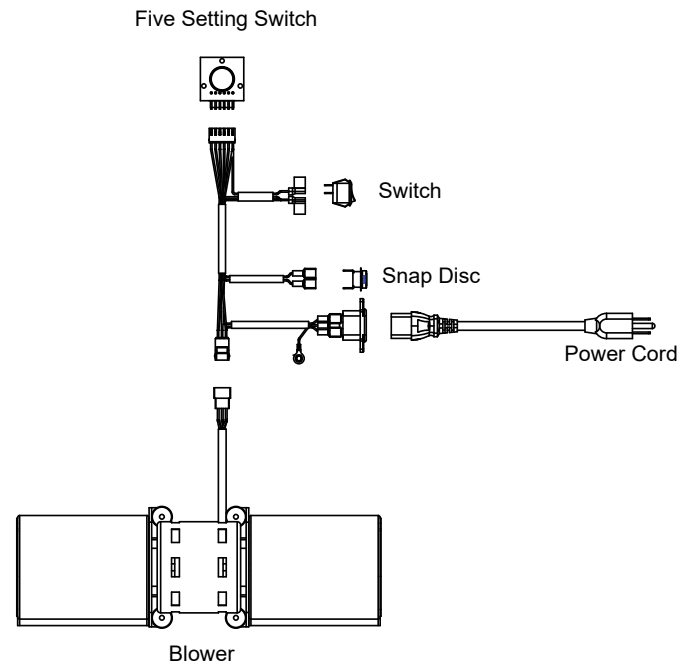

Figure 23.3

## G. Door Handle

Service Part: SRV7063-014

1. Install washer on door handle shaft.
2. Slide door handle through door.
3. Install additional washer(s) as shown in **Figure 23.4**.
4. Install key in groove.
5. Align groove in latch cam with key; slide latch cam over shaft
6. Install locknut but do not over tighten, the handle needs to move smoothly.
7. Install handle turning in a counter-clockwise motion to desired location on door handle rod (**Figure 23.4**).

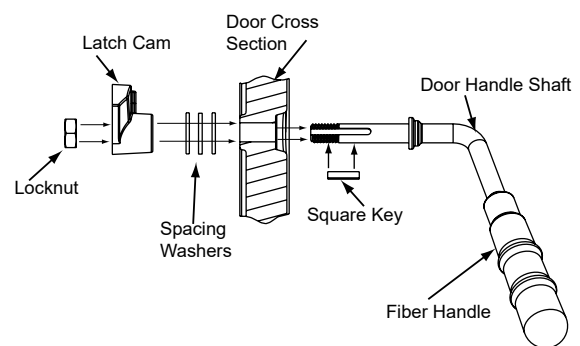

Figure 23.4



### CAUTION

**DO NOT** over tighten lock nut. The door handle needs to move smoothly.

## H. Tube Channel

**Service Part: SRV7095-016**

1. Remove the 3 right side bricks.
2. Remove the baffle protection channel by bending back the tabs using needle nose pliers located at the right and left side of the protection cover. Lift the cover up slightly and pull toward the front and out of the firebox (**Figure 24.2**).
3. Locate the 2 channel nuts and two bolts inside of chamber and remove using a 7/16 socket wrench for the nuts and a 3/8 socket wrench for the bolts (**Figure 24.3**).

**NOTE:** Soak the bolts with penetrating oil for at least 15 minutes before trying to remove them.

4. Slide the tube channel assembly all the way to left until it is off the threads. Drop the right side down, then slide the assembly back to right (**Figure 24.1**).
5. The ceramic blanket and both baffle boards can be removed at the same time you remove the tube channel assembly.
6. When the tube channel assembly is free of the left side support, rotate clockwise and pull assembly, blanket and baffles out through the front opening.
7. Re-install in reverse order.

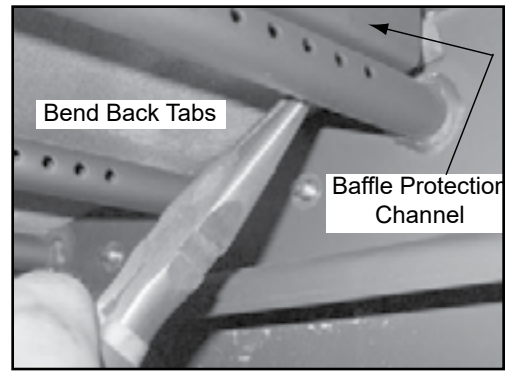

Figure 24.2

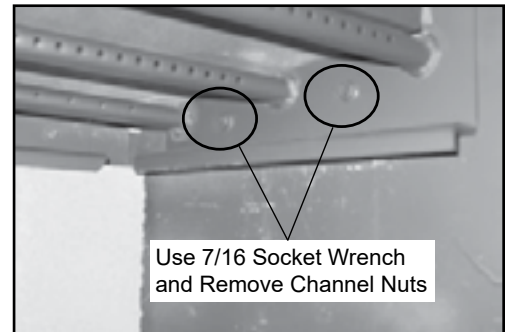

Figure 24.3

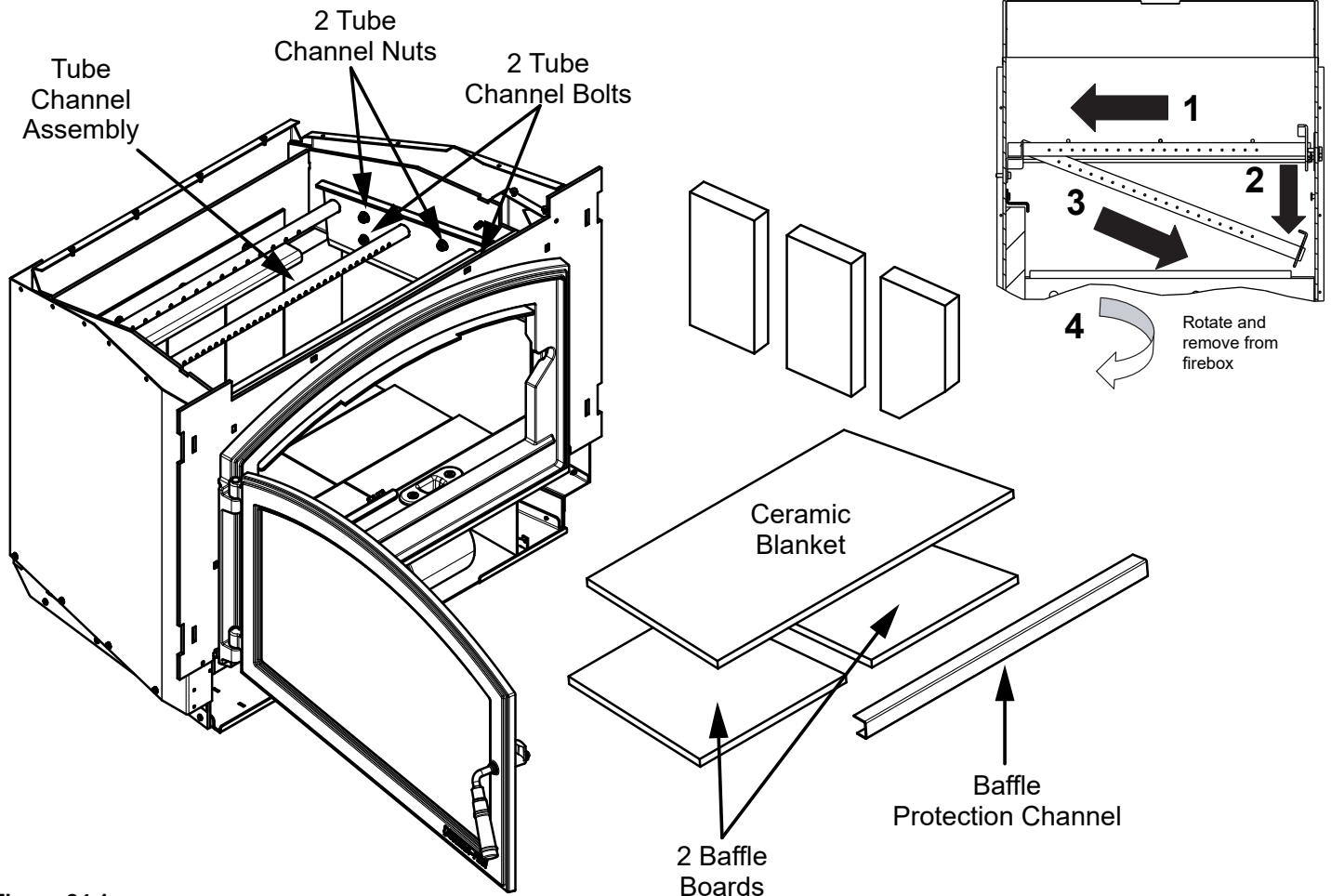

Figure 24.1



# 6 Reference Materials

---

## A. Service and Maintenance Log

Date of Service	Performed By	Description of Service



Date of Service	Performed By	Description of Service



B. Exploded View

**QUADRA-FIRE**<sup>®</sup>

Service Parts

**EXPEDITION-II**

Cast Iron Wood Insert - Large

Beginning Manufacturing Date: Sept 2019  
Ending Manufacturing Date: Active

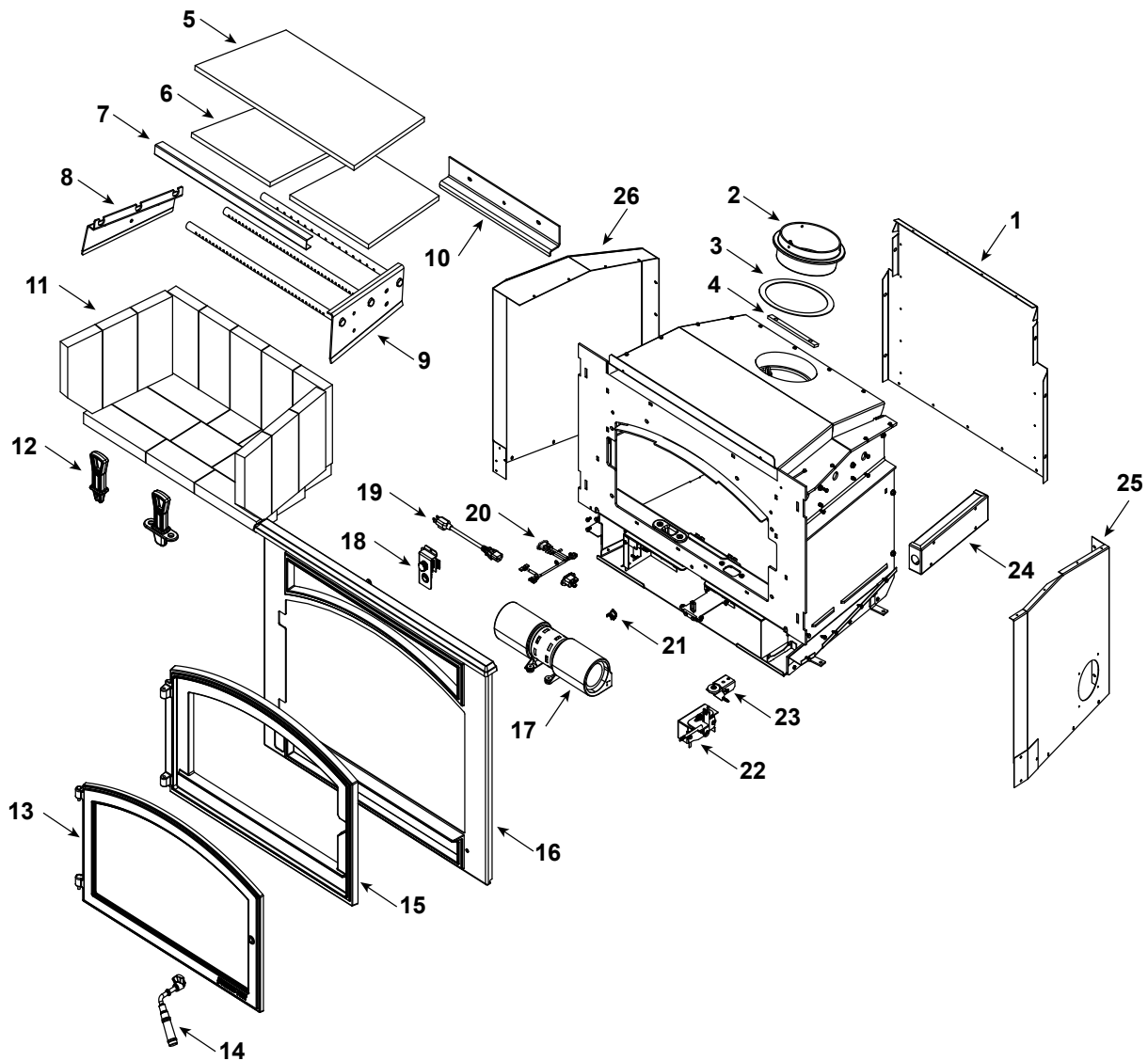

Part number list on following page.

07/20

C. Service Parts



Service Parts

EXPEDITION-II

Beginning Manufacturing Date: Sept 2019  
Ending Manufacturing Date: Active

IMPORTANT: THIS IS DATED INFORMATION. Parts must be ordered from a dealer or distributor. **Hearth and Home Technologies does not sell directly to consumers.** Provide model number and serial number when requesting service parts from your dealer or distributor.



Stocked at Depot

ITEM	DESCRIPTION	COMMENTS	PART NUMBER	
1	Convection Back		SRV7095-161	
	Hurricane Screw	Pkg of 40	SRV2005-861/40	Y
	Screw, Hwh Ms 1/4-20 X 3/4 Ns	Pkg of 25	220-0080/25	Y
2	Flue Attach Ring		SRV7095-203	
	Bolt 5/16 X 18 X 1		7000-571	Y
	Nut, 5/16-18	Pkg of 10	A-3483-1/10	Y
3	Gasket, Flue Collar		SRV7044-194	
4	Chimney Ring Attach		SRV7044-181	
5	Ceramic Fiber Blanket		SRV7095-118	Y
6	Baffle Board	Pkg of 2	SRV7095-117	Y

#7 Baffle Protection Channel

Side view

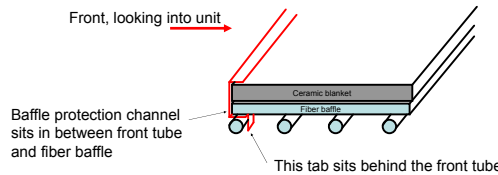

7	Baffle Protection Channel		SRV7095-119	Y
8	Tube Support Rack		SRV7095-124	
	Screw, Hwh Ms 1/4-20 X 3/4 Ns	Pkg of 25	220-0080/25	Y
9	Tube Channel Assembly		SRV7095-016	
	Screw, Hwh Ms 1/4-20 X 3/4 Ns	Pkg of 25	220-0080/25	Y
	Nut, Flange 1/4-20	Pkg of 24	226-0130/24	Y
10	Rear Brick Retainer		SRV7095-127	
	Screw, Hwh Ms 1/4-20 X 3/4 Ns	Pkg of 25	220-0080/25	Y

#11 Brick Assembly

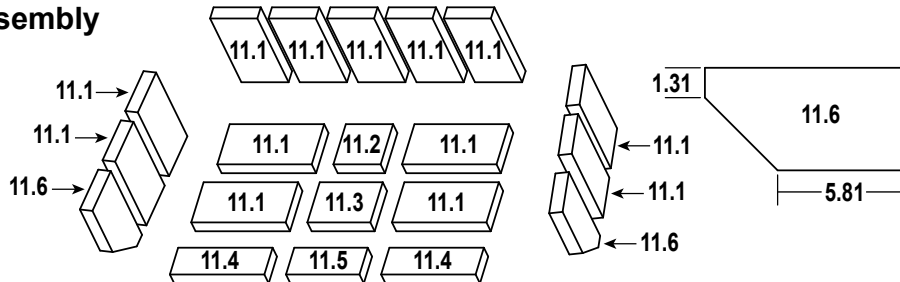

11	Brick Assembly		SRV7095-022	Y
11.1	Brick, Uncut	Qty. 13 Req	832-0550	Y
11.2	Brick, 4.5" X 4.5" X 1.25"	Qty. 1 Req	SRV7128-001	
11.3	Brick, 5.75" X 4.5" X 1.25"	Qty. 1 Req	SRV7128-039	
11.4	Brick, 9" X 3" X 1.25"	Qty. 2 Req	SRV7128-003	
11.5	Brick, 7" X 3" X 1.25"	Qty. 1 Req	SRV7128-004	
11.6	Brick, 9" X 4.5" X 1.25" W/Angle	Qty. 2 Req	SRV7128-600	
	Brick, Uncut	Pkg of 6	832-3040	

Additional service part numbers appear on following page.

IMPORTANT: THIS IS DATED INFORMATION. Parts must be ordered from a dealer or distributor. **Hearth and Home Technologies does not sell directly to consumers.** Provide model number and serial number when requesting service parts from your dealer or distributor.



**Stocked at Depot**

ITEM	DESCRIPTION	COMMENTS	PART NUMBER	
12	Andiron	2 Sets	SRV7061-020	
	Screw Fh Tx 1/4-20 x 1		7000-622/10	Y

### #13 Door Assembly

### #14 Door Handle Assembly

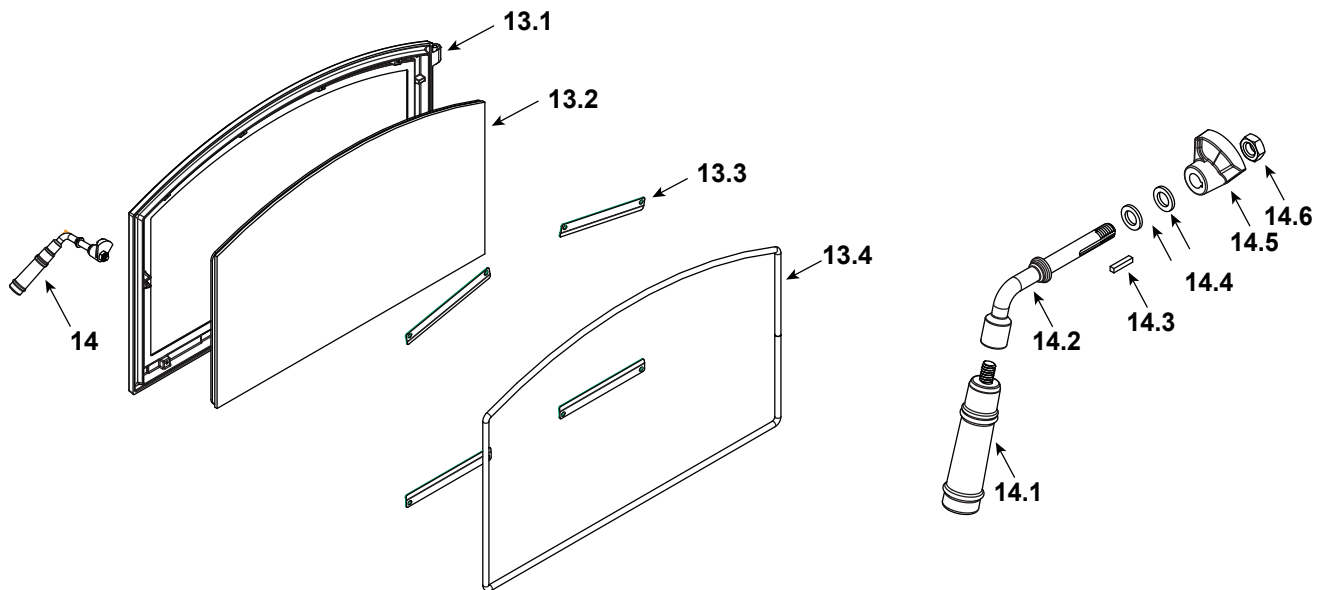

13	Door Assembly		SRV7095-053	
13.1	Door		SRV7095-205	
13.2	Glass Assembly		SRV7095-054	
13.3	Glass Retainers	Qty 4 req	SRV7061-205	
	Screw, Pan Head Phillips, 8-32 x 3/8	Pkg of 40	225-0500/40	Y
13.4	Door Gasket	15 FT	1-00-1203589	Y
14	Door Handle Assembly		SRV7063-014	Y
14.1	Fiber Handle		SRV7060-212	Y
14.2	Door Handle		SRV7063-137	
14.3	Key, cam Latch		SRV430-1151	
14.4	Washer, Sae 3/8 ( 3 ea)	Pkg of 3	832-0990	Y
14.5	Cam Latch		SRV430-1141	
14.6	Nut, Side Lock Jam	Pkg of 24	226-0100/24	Y
15	Front		SRV7095-201	
	Wire Jacket Rope, 1/2		7000-811/10	

Additional service part numbers appear on following page.

IMPORTANT: THIS IS DATED INFORMATION. Parts must be ordered from a dealer or distributor. **Hearth and Home Technologies does not sell directly to consumers.** Provide model number and serial number when requesting service parts from your dealer or distributor.



**Stocked  
at Depot**

ITEM	DESCRIPTION	COMMENTS	PART NUMBER
------	-------------	----------	-------------

**#16 Fascia Assembly**

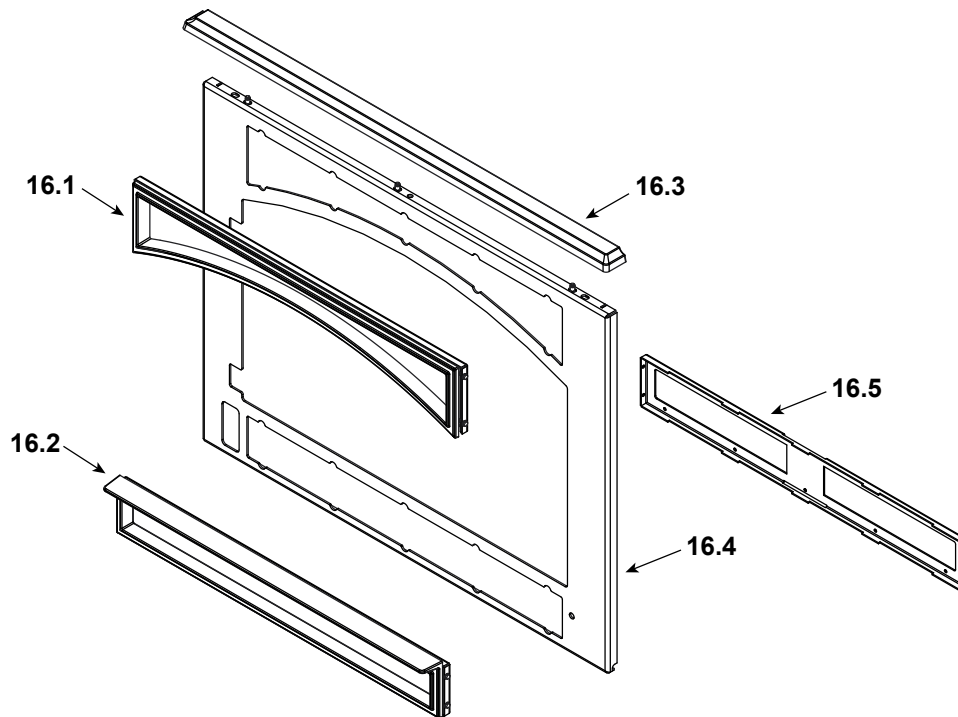

16	Fascia Assembly		SRV7095-057	
16.1	Front Trim, Upper (w/Screen)		SRV7095-209	
	Screw, Pan Head phillips 8-32 x 3/8	Pkg of 40	225-0500/40	Y
16.2	Front Trim, Lower (w/Screen)		SRV7095-211	
	Screw, Pan Head phillips 8-32 x 3/8	Pkg of 40	225-0500/40	Y
16.3	Fascia Top		SRV7095-207	
	Button Head 1/4-20 X .5	Pkg of 20	832328/20	Y
16.4	Fascia Weldment		SRV7095-061	
16.5	Trim Mount Bottom		SRV7095-222	
17	Blower Replacement		SRV7000-868	Y

Additional service part numbers appear on following page.



IMPORTANT: THIS IS DATED INFORMATION. Parts must be ordered from a dealer or distributor. **Hearth and Home Technologies does not sell directly to consumers.** Provide model number and serial number when requesting service parts from your dealer or distributor.



**Stocked at Depot**

ITEM	DESCRIPTION	COMMENTS	PART NUMBER
------	-------------	----------	-------------

**#18 Control Panel Assembly**

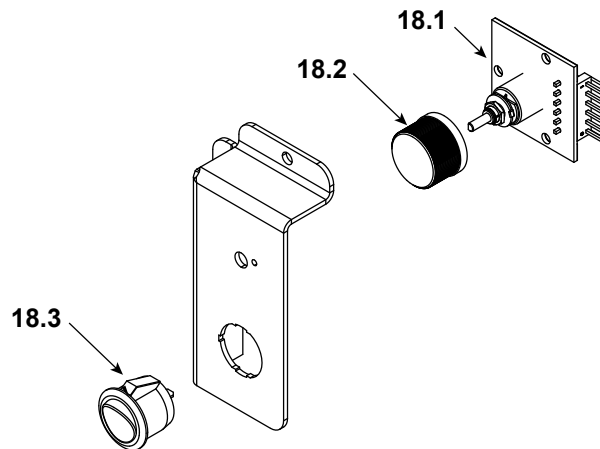

18	Control Panel Assembly		SRV7095-026	
18.1	Speed Control		SRV7000-888	Y
18.2	Knob, Speed Control		SRV7000-930	Y
18.3	Rocker Switch (Round)		SRV7000-940	Y
19	Power Cord		812-1180	Y
20	Wire Harness		SRV7000-891	Y
21	Snap Disc, #1, Convection Blower		SRV230-0470	Y
22	Timer Control Assembly		SRV7095-025	Y
	Knob	Pkg of 2	32284/2	Y
	Screw, Pan Head phillips 8-32 x 3/8	Pkg of 40	225-0500/40	Y
	Timer (Only) Replacement Assembly		SRV480-1940	Y
23	Timer Door Assembly		SRV7075-054	Y
	Door Gasket		7033-282	Y
	Screw, Machine Screw 1/4-20 x 3/4 Ns	Pkg of 25	220-0080/25	Y
24	Tube Channel Base Assembly		SRV7095-125	
	Screw, Machine Screw 1/4-20 x 3/4 Ns	Pkg of 25	220-0080/25	Y
	Hurricane Screw	Pkg of 40	SRV2005-861/40	Y

Additional service part numbers appear on following page.

D. Accessories

Beginning Manufacturing Date: Sept 2019  
Ending Manufacturing Date: Active

IMPORTANT: THIS IS DATED INFORMATION. Parts must be ordered from a dealer or distributor. **Hearth and Home Technologies does not sell directly to consumers.** Provide model number and serial number when requesting service parts from your dealer or distributor.



**Stocked at Depot**

ITEM	DESCRIPTION	COMMENTS	PART NUMBER	
25	Combustion Cover		SRV7095-134	
	Hurricane Screw	Pkg of 40	SRV2005-861/40	Y
26	Convection Side Panel		SRV7095-166	
	Component Pack		SRV7095-062	
	Surround 43 x 31		SP2-4331	
	Surround Trim Assembly 43 x 31		TRIMKIT-4331-NL	
	Surround 51 x 34		SP2-5134	
	Surround Trim Assembly 51 x 34		TRIMKIT-5143-NL	
	Surround Cast Trim 43 x 31		CT2-4331	
	Surround Cast Trim 51 x 34		CT2-5134	

**#27 Cast Trim**

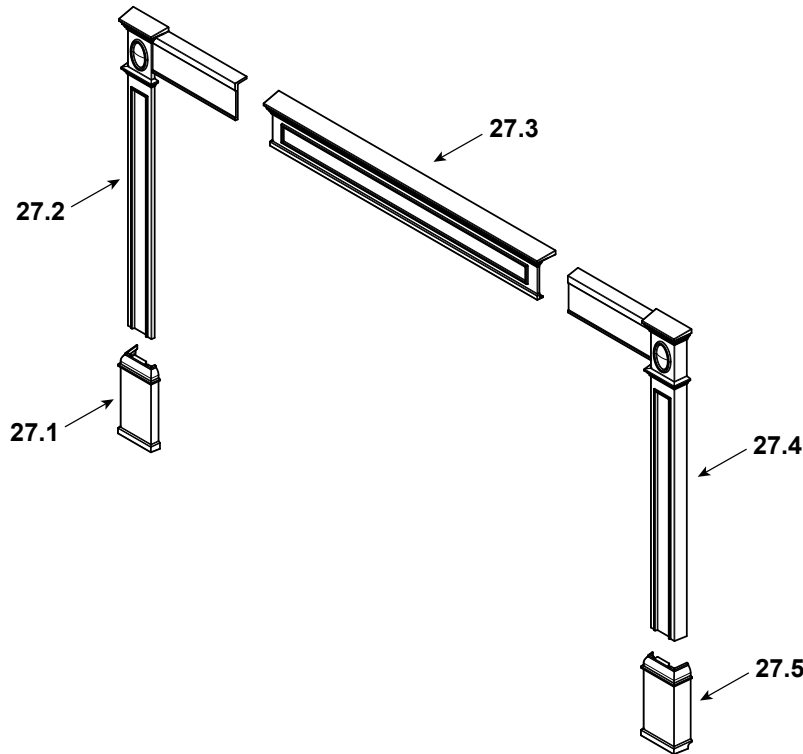

27	Trim Cast, Full Set		811-0930	
27.1	Footer, Left		414-7090MBK	
27.2	Trim Leg, Left		414-7120MBK	
27.3	Header		414-7110MBK	
27.4	Trim Leg, Right		414-7130MBK	
27.5	Footer, Right		414-4100MBK	
	15 Degree Adapter		DV-6DLR-E15ADSS	

Additional service part numbers appear on following page.

Beginning Manufacturing Date: Sept 2019  
Ending Manufacturing Date: Active

IMPORTANT: THIS IS DATED INFORMATION. Parts must be ordered from a dealer or distributor. **Hearth and Home Technologies does not sell directly to consumers.** Provide model number and serial number when requesting service parts from your dealer or distributor.



Stocked at Depot

ITEM	DESCRIPTION	COMMENTS	PART NUMBER	Stocked at Depot
	Hurricane Screw	Pkg of 40	SRV2005-861/40	Y
	Screw, Hex Washer Head Ms 1/4-20 x 3/4	Pkg of 25	220-0080/25	
	Bolt (5/16 x 18 x 1)	Pkg of 12	27887/12	Y
	Nut (5/16 -18)	Pkg of 10	A-3483-1/10	Y
	Nut flange (1/4-20)	Pkg of 24	226-0130/24	Y
	Screw, FH HX (1/4-20 x 1)	Pkg of 6	7000-622/6	Y
	Screw, Pan Head Phillips (8-32 X 3/8)	Pkg of 40	225-0500/40	Y
	Washer, SAE, 3/8 (3 Ea)	Pkg of 3	832-0990	Y
	Nut 2-wy Side- Lock Jam 3	Pkg of 24	226-0100/24	Y
	Bolt, Hex Washer Head Serrated Flange 1/4-20 x 3/4	Pkg of 25	228-0120/25	
	Washer, Bonded 5/16 x 3/4	Pkg of 10	229-0910/10	
	Screw, Flat Head Phillips 8-32 x 1/2	Pkg of 12	220-0490/12	
	Bumper, Rubber	Pkg of 12	SRV224-0340/12	Y
	Wire Clip	Pkg of 10	7000-400/10	Y
	Knob, Speed Control		SRV7000-930	Y
	1/4-20 x 50 Phillips Pan Head Screw	Pkg of 12	32281/12	
	Screw, Phillips Button Head 1/4-20 X 3/8	Pkg of 24	7000-401/24	Y

# QUADRA-FIRE®

NOTHING BURNS LIKE A QUAD

## CONTACT INFORMATION

Hearth & Home Technologies  
352 Mountain House Road  
Halifax, PA 17032  
Division of HNI INDUSTRIES

Please contact your Quadra-Fire dealer with any questions or concerns.  
For the number of your nearest Quadra-Fire dealer  
log onto [www.quadrafire.com](http://www.quadrafire.com)



## CAUTION



### DO NOT DISCARD THIS MANUAL

- Important operating and maintenance instructions included.
- Read, understand and follow these instructions for safe installation and operation.
- Leave this manual with party responsible for use and operation of this appliance.



### We recommend that you record the following pertinent information for your heating appliance.

Date purchased/installed: \_\_\_\_\_

Serial Number: \_\_\_\_\_

Location on appliance: \_\_\_\_\_

Dealership purchased from: \_\_\_\_\_

Dealer Phone: 1(     ) - \_\_\_\_\_

Notes:  
\_\_\_\_\_  
\_\_\_\_\_  
\_\_\_\_\_

This product may be covered by one or more of the following patents: (United States) 5341794, 5263471, 6688302, 7216645, 7047962 or other U.S. and foreign patents pending.

  
**HEARTH & HOME**  
technologies™