



DISCOVERY SERIES
STEEL WOOD STOVES

QUADRA-FIRE
NOTHING BURNS LIKE A QUAD

QUADRA-FIRE®

PERFORMANCE FROM THE BEGINNING



In 1990, the U.S. Environmental Protection Agency (EPA) enacted stringent wood-burning regulations, crippling the more than 500 wood stove manufacturers around the country. But not Quadra-Fire®.

Two years of research and development later, founders Alan Trusler and Dan Henry unveiled their patented “Quad Burn” system. The technology produced powerful and efficient rolling flames so intense, it dawned the inception of the Quadra-Fire name.



In 2015 and 2020, the U.S. Environmental Protection Agency updated their regulations requiring even tougher standards on emissions. Using our existing technology, Quadra-Fire was able to exceed these new standards ensuring renewable heat sources for generations to come.

WHY QUADRA-FIRE

At Quadra-Fire we believe that nothing burns like a Quad, and heating with wood should be easy and cost effective. Today these ideals are vibrant and alive, blending our past with our present. Quadra-Fire products are proudly built to last by our members.

WHY WOOD

IT'S RENEWABLE - Using renewable energy sources is more important than ever and wood is 100 percent renewable. When you burn wood, you are also completing the last step of the natural carbon cycle of trees, resulting in a zero net carbon impact on the environment.

IT'S COST-EFFECTIVE - Heating with wood costs less than heating with electricity, liquid propane or heating oil, especially if you harvest wood yourself.

As the fire ignites, it remains clear:

NOTHING BURNS LIKE A QUAD.

COVER: DISCOVERY II SHOWN WITH CUSTOM TILE



QUADRA-FIRE

DISCOVER THE POSSIBILITIES

The Discovery Series offers three sizes to fit any of your heating needs and the convenience of a space-saving wood storage bin designed right into the stove.

You can easily personalize your stove by adding 12" x 12" ceramic tiles to the side panels or paint the solid side panel any color using high temperature paint.



EXCLUSIVE TECHNOLOGIES

Innovative technology is at work in every Quadra-Fire. These advancements make it possible to burn wood more effectively, efficiently, and with more control.

FOUR-POINT BURN SYSTEM

The patented Quadra-Fire Four-Point Burn System produces intense rolling flames. Four combustion cycles extend the heat, enhance the fire and increase efficiency for long-lasting, proven performance.

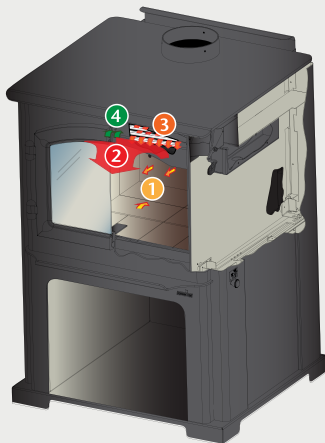

1. PRECISION START-UP

Airflow quickly routes to the heart of the fire.

2. SECONDARY BURN ZONE

Air movement helps create rolling flames and keeps the glass clean.

3. TERTIARY BURN ZONE

Superheated air ignites flammable gases rising from the wood.

4. QUATERNARY BURN ZONE Remaining impurities are burned above the baffle before exiting up the chimney.

AUTOMATIC COMBUSTION CONTROL

Automatic Combustion Control (ACC) is an advanced heat-management technology from Quadra-Fire. ACC feeds the fire with air when it's needed most—for precision start-up or a boost of air when needed.

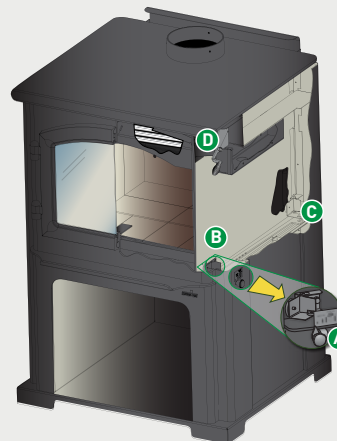

A. ACTIVATION CONTROL KNOB

Push back and pull forward to activate start-up airflow.

B. ACC AIR INLET

Controls start-up airflow to build the fire.

C. ACC TIMER

Opens ACC air inlet during start-up for approximately 20 minutes.

D. BURN RATE CONTROL Controls the airflow feeding the fire, also controls your comfort.

DISCOVERY III



DISCOVERY III SHOWN WITH CUSTOM TILE

Peak
BTU/hr Output¹
61,700

Heating Capacity²
**1,100-
3,000 sq ft**

Max. Burn Time³
12 hrs

Efficiency⁵
80.2%

Emissions
1.6 g/hr

Firebox
2.3 cu ft

Recommended
Log Length
18"

Viewing Area
165 sq in

Actual Weight
360lb



DISCOVERY III

Shown above without tile kit or solid side panel.

PERSONALIZE YOUR STOVE

Use any 11-3/4" x 11-3/4" x 3/8" ceramic tile, available at any tile and flooring retailer, or use the solid side panel, which can be painted using a high temperature paint.

DISCOVERY II



DISCOVERY II SHOWN WITH CUSTOM PAINTED SOLID SIDE PANEL

Peak BTU/hr Output ¹ 51,000	Heating Capacity ² 1,000- 2,600 sq ft	Max. Burn Time ³ 10 hrs	Efficiency ⁵ 78.3%	Emissions 1.9 g/hr	Firebox 2.0 cu ft	Recommended Log Length 16"	Viewing Area 165 sq in	Actual Weight 339lb
---	--	--	---	------------------------------	-----------------------------	---	----------------------------------	-------------------------------



DISCOVERY II

Shown above without tile kit or solid side panel.

PERSONALIZE YOUR STOVE

Use any 11-3/4" x 11-3/4" x 3/8" ceramic tile, available at any tile and flooring retailer, or use the solid side panel, which can be painted using a high temperature paint.

DISCOVERY I



DISCOVERY I SHOWN WITH CUSTOM TILE

Peak
BTU/hr Output¹
44,400

Heating Capacity²
**800-
2,100 sq ft**

Max. Burn Time³
7 hrs

Efficiency⁵
82.3%

Emissions
1.7 g/hr

Firebox
1.5 cu ft

Recommended
Log Length
16"

Viewing Area
125 sq in

Actual Weight
285lb



DISCOVERY I

Shown above without tile kit or solid side panel.

PERSONALIZE YOUR STOVE

Use any 11-3/4" x 11-3/4" x 3/8" ceramic tile, available at any tile and flooring retailer, or use the solid side panel, which can be painted using a high temperature paint.

ACCESSORIES



FAN KIT
ALL STOVES

PERSONALIZE YOUR STOVE

TILE PANELS (DISCOVERY III AND II USE THREE TILES PER SIDE. DISCOVERY I USES TWO TILES PER SIDE)



SOLID PANELS CUSTOMIZE YOUR STOVE BY PAINTING THE SIDE PANELS WITH HIGH TEMPERATURE PAINT (RATED ABOVE 300 DEGREES)

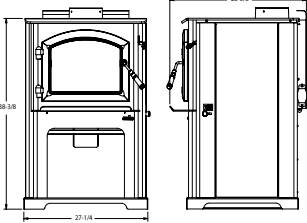
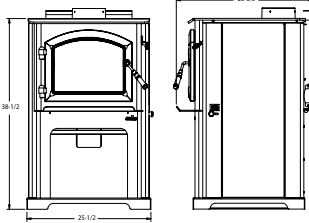
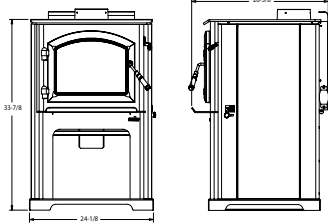

STOVE COMPARISON

DISCOVERY III	DISCOVERY II	DISCOVERY I
		
PEAK BTU/HR OUTPUT¹ » 61,700	PEAK BTU/HR OUTPUT¹ » 51,000	PEAK BTU/HR OUTPUT¹ » 44,400
HEATING CAPACITY² » 1,100 - 3,000 sq. ft.	HEATING CAPACITY² » 1,000 - 2,600 sq. ft.	HEATING CAPACITY² » 800 - 2,100 sq. ft.
MAXIMUM BURN TIME³ » 12 hrs	MAXIMUM BURN TIME³ » 10 hrs	MAXIMUM BURN TIME³ » 7 hrs
EFFICIENCY⁵ » 80.2%	EFFICIENCY⁵ » 78.3%	EFFICIENCY⁵ » 82.3%
EMISSIONS » 1.6 g/hr	EMISSIONS » 1.9 g/hr	EMISSIONS » 1.7 g/hr
FIREBOX CAPACITY » 2.3 cu ft	FIREBOX CAPACITY » 2.0 cu ft	FIREBOX CAPACITY » 1.5 cu ft
RECOMMENDED LOG LENGTH » 18" max.	RECOMMENDED LOG LENGTH » 16" max.	RECOMMENDED LOG LENGTH » 16" max.
VIEWING AREA » 165 sq in	VIEWING AREA » 165 sq in	VIEWING AREA » 125 sq in
ACTUAL WEIGHT » 360lb	ACTUAL WEIGHT » 339lb	ACTUAL WEIGHT » 285lb

CLEARANCES TO COMBUSTIBLES

DISCOVERY SERIES		A	B	C	D	E	F	G
Discovery III	Single Wall Pipe	18-1/2"	11-3/4"	27-1/2"	14-1/2"	8"	20-1/2"	53-1/2"
	Double Wall Pipe	12"	5-1/4"	27-1/2"	14-1/2"	8"	20-1/2"	53-1/2"
Discovery II	Single Wall Pipe	18-1/4"	11-3/4"	28-1/2"	16"	8"	20"	48"
	Double Wall Pipe	13-1/2"	6-1/2"	25"	13"	6-1/2"	18-1/2"	48"
Discovery I	Single Wall Pipe	18"	11"	24-1/2"	13"	8-1/2"	20"	56"
	Double Wall Pipe	11-3/4"	5"	23"	11-1/2"	7-1/2"	19"	43"

Backwall / Sidewall

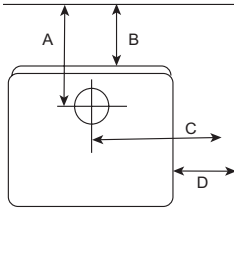

Corner Installation

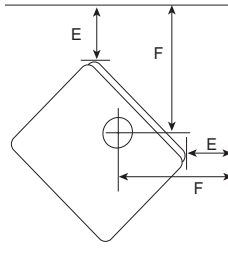

Stove to Ceiling Clearance

*Follow pipe manufacturer's clearances as required

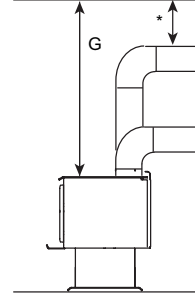

HEARTH PROTECTION

	Hearthpad Type	A	B	C	D	E	F	G	H	I	J	K	L
Discovery III	Type I	8"	16"	15-5/8"	41"	31-5/8"	50-1/4"	15-5/8"	39"	63-1/4"	50-1/4"	39"	63-1/4"
Discovery II	Type I	8"	16"	15-5/8"	39"	31-5/8"	47-1/8"	15-5/8"	38"	58-3/4"	48-5/8"	37-1/2"	60-7/8"
Discovery I	Type I	8"	16"	13-5/8"	39"	29-5/8"	46-3/4"	13-5/8"	37-1/8"	59-1/4"	47-3/4"	38-1/8"	60-5/8"

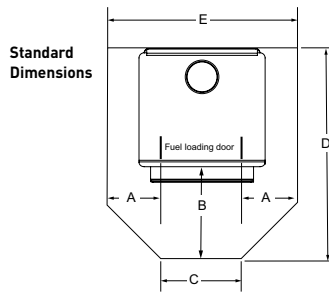

Corner Dimensions w/
Double Wall Pipe

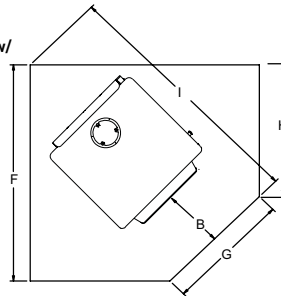

Corner Dimensions w/
Single Wall Pipe

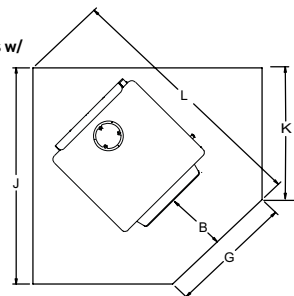

Thank you from everyone at Quadra-Fire

Available From:

QUADRA-FIRE
NOTHING BURNS LIKE A QUAD

www.quadrafire.com | 800-926-4356

Limited Lifetime Warranty⁴

The strongest in the industry, Quadra-Fire provides a limited lifetime warranty on the most important aspects: firebox and heat exchanger.

facebook.com/QuadraFire
twitter.com/QuadraFire
youtube.com/QuadraFirePower

1: BTU: First hour output uses high burn efficiency number. BTU will vary depending on the type of fuel used and moisture content of the fuel. 2: Heating capacity (in square feet) is a guideline only and may differ due to climate, building construction and condition, amount and quality of insulation, location of the heater, and air movement in the room. 3: Actual burn times will vary based on how the appliance is operated, load size, moisture content and type of wood used, chimney height and installation. 4: For full warranty details go to www.quadrafire.com. 5: Weighted average LHV (low heating value) efficiency.

IMPORTANT - READ BEFORE YOU INSTALL! - Refer to the Owner/Installation Manual for complete clearance requirements and specifications. The images and descriptions in this brochure are provided to assist you in product selection only.

Quadra-Fire is a registered trademark of Hearth & Home Technologies. Product specifications and pricing subject to change without notice.

Fireplace, stove and insert surfaces get extremely HOT and can cause burns if touched. Keep a safe distance away. To learn more visit www.quadrafire.com/fireplacesafety